

ACGWS  
AEVSC/M  
WIDIA /  
KENNAMETAL

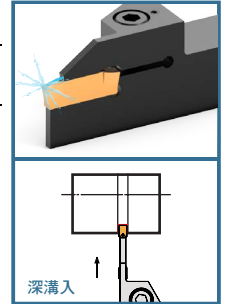

ACGWS

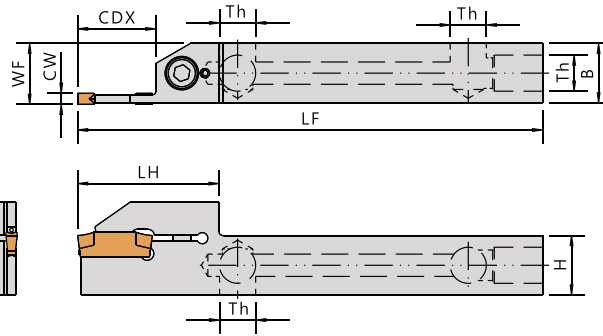

AEVSM

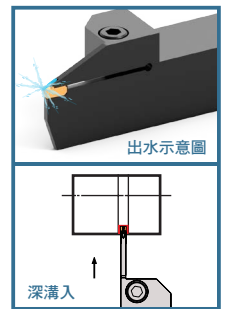
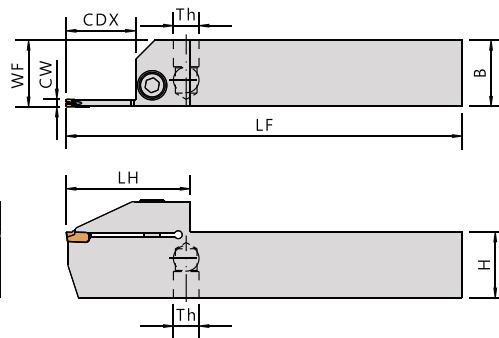

- Direct coolant supply through the turning tool.
- Shorten processing time by high cutting speed.
- 30 to 150% longer tool life for different kind of materials.
- Improved chip breaking, particularly at pressures above 40 bar.

▼ Recommended Inserts 建議刀片品牌：WIDIA

Order No.	Insert	Dimensions(mm)								Parts				Wrench
		柄高	柄寬	總長	寬度	頭長	切寬	切深	牙孔	刀片螺絲	止付螺絲	轉接頭	板手	
Right / Left		H	B	LF	WF	LH	CW	CDX	Th					
ACGWSR16B-3D40J	WU25PT	16	16	125	16	38	3	20	1/8"	CSH0516	CS9NQ	-	LW040	
ACGWSR20B-5D50J		20	20	125	20	42	5	25	1/8"		CS9-3003 CS9-25025			

▼ Recommended Inserts 建議刀片品牌：KENNAMETAL / WIDIA

Order No.	Insert	Dimensions(mm)								Parts				Wrench
		柄高	柄寬	總長	寬度	頭長	切寬	切深	牙孔	刀片螺絲	止付螺絲	轉接頭	板手	
Right / Left		H	B	LF	WF	LH	CW	CDX	Th					
AEVSCR/L-1616K0216	EC020 WU16PT	16	16	125	16.35	27	2	8	1/8"	CS40090	CS9NQ CS9-2002	-	TL-15 LW040	
AEVSMR/L-2525M0326	EC030 WU25PT	25	25	150	25.25	43	3	13	1/8"	CSH0520		-	LW040	

# Grooving Tools 槽刀

ADGT

ISCAR / WIDIA

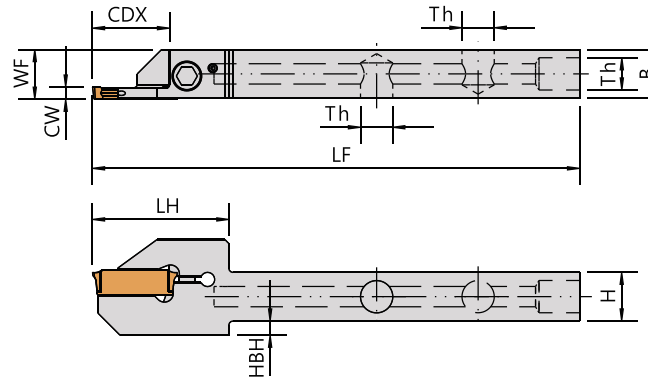
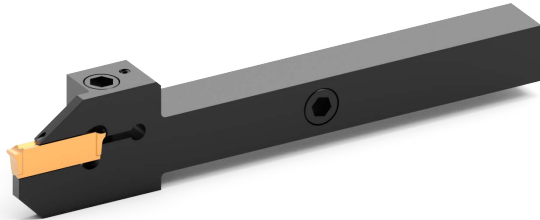
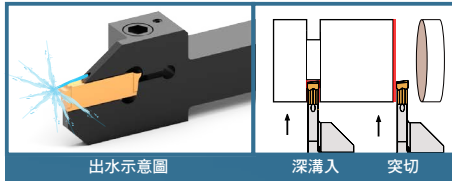

▼Recommended Inserts 建議刀片品牌：ISCAR / WIDIA

Order No.	Insert	Dimensions(mm)									Parts			Wrench
		柄高 H	柄寬 B	總長 LF	寬度 WF	頭長 LH	切寬 CW	切深 CDX	下巴厚 HBH	牙孔 Th	刀片螺絲	止付螺絲	轉接頭	板手
ADGTR12B-2D24JS (100L)	DGR 2002Z-6D WDGN2202J	12	12	100	12.28	27	2	12	3.5	5/16"	CSH0412	CS9NN CS9-2002	CS9NP	LW030 LW040
ADGTR/L12B-2D26J		12	12	120	12.28	28	2	13	3.5	5/16"			-	
ADGTR/L12B-2D26JCB		12	12	140	12.28	28	2	13	3.5	5/16"			-	
ADGTR12B-2D26JS		12	12	120	12.28	28	2	13	3.5	5/16"			-	
ADGTL12B-2D26JU		12	12	120	12.28	28	2	13	3.5	5/16"		CS9NN CS9-25025	CS9NP	
ADGTR/L12B-2D36J		12	12	120	12.28	33	2	18	3.5	5/16"			CS9NP	
ADGTR/L12B-2D36JS		12	12	120	12.28	33	2	18	3.5	5/16"			CS9NP	
ADGTR/L12B-2D36JCB		12	12	140	12.28	33	2	18	3.5	5/16"			-	
ADGTR/L12B-3D36J	DGR 3003Z-6D WDGN3102J	12	12	120	12.25	33	3	18	3.5	5/16"	CSH0414	CS9NQ CS9-2002	CS9NP	
ADGTL12B-3D36JCB		12	12	140	12.25	33	3	18	3.5	5/16"		-		
ADGTR16B-2D24J	WDGN2202J TN6025	16	16	120	16.275	27	2	12	-	1/8"	CSH0412	CS9NQ CS9-2002	-	LW030
ADGTR/L16B-2D26J		16	16	120	16.275	28	2	13	-	1/8"			-	
ADGTL16B-2D26JCB		16	16	140	16.275	28	2	13	-	1/8"			-	
ADGTR16B-2D26JS		16	16	120	16.275	28	2	13	-	1/8"			-	
ADGTR/L16B-2D36JCB		16	16	140	16.275	33	2	18	-	1/8"			-	
ADGTL16B-2D36JF		16	16	120	16.275	33	2	18	-	1/8"			-	
ADGTR16B-2D36JS		16	16	120	16.275	33	2	18	-	1/8"			-	
ADGTL16B-2D36JSCB		16	16	140	16.275	33	2	18	-	1/8"			-	
ADGTR/L16B-3D40J	DGR 3003Z-6D	16	16	120	16.25	35	3	20	-	1/8"	CSH0414	-	-	
ADGTL16B-3D40JS		16	16	120	16.25	35	3	20	-	1/8"		-		
ADGTR/L20B-2D36JS	WDGN2202J TN6025	20	20	125	20.275	33	2	18	-	1/8"	CSH0516	CS9NQ CS9-2002	-	LW040
ADGTR/L20B-3D40J	DGR 3003Z-6D	20	20	125	20.25	35	3	20	-	1/8"			-	
ADGTL20B-3D40JS		20	20	125	20.25	35	3	20	-	1/8"			-	
ADGTR/L20B-3D44JS		20	20	125	20.25	37	3	22	-	1/8"				
ADGTR25B-2D36J	WDGN2202J TN6025	25	25	150	25.275	33	2	18	-	1/8"	CSH0516	CS9NQ CS9-2002	-	LW040
ADGTR25B-2D36JS		25	25	150	25.275	33	2	18	-	1/8"			-	
ADGTL25B-3D40J	DGR 3003Z-6D	25	25	150	25.25	35	3	20	-	1/8"			-	
ADGTR25B-3D40JS		25	25	150	25.25	35	3	20	-	1/8"			-	

# Grooving Tools 槽刀

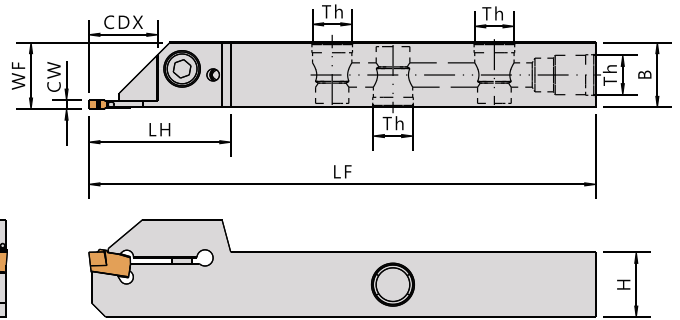
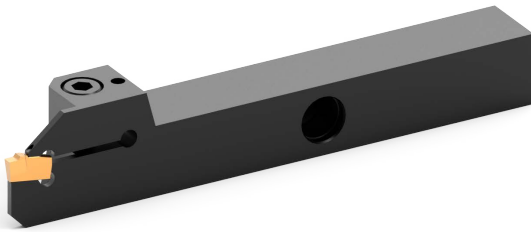
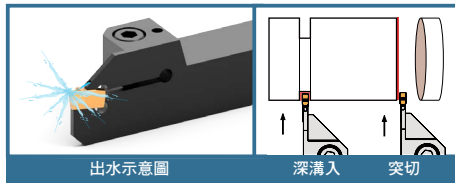
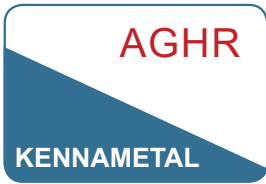

## ▼ Recommended Inserts 建議刀片品牌 : KENNAMETAL

Order No.	Insert	Dimensions(mm)								Parts			Wrench
		柄高	柄寬	總長	寬度	頭長	切寬	切深	牙孔	刀片螺絲	止付螺絲	轉接頭	板手
Right / Left		H	B	LF	WF	LH	CW	CDX	Th				
AGHR/L-1212K02-12	A2022	12	12	125	12.4	30	2	12	5/16"	CSH0514	CS9NN CS9-3003	CS9NP	LW040
AGHR/L-1616K02-12	A2G02	16	16	125	16.4	33	2	12	1/8"		CS9NQ CS9-3003		
AGHR/L-1616K03-16	A2030 A3G03	16	16	125	16.4	37	3	16	1/8"	-	CS9NQ CS9-3003	-	
AGHR/L-1616K03-20		16	16	125	16.4	41	3	20	1/8"		CS9NQ CS9-3003		
AGHR/L-2525M03-26		25	25	150	25.4	47	3	26	1/8"		CS9NQ CS9-3003		

- Direct coolant supply through the turning tool.
- Shorten processing time by high cutting speed.
- 30 to 150% longer tool life for different kind of materials.
- Improved chip breaking, particularly at pressures above 40 bar.

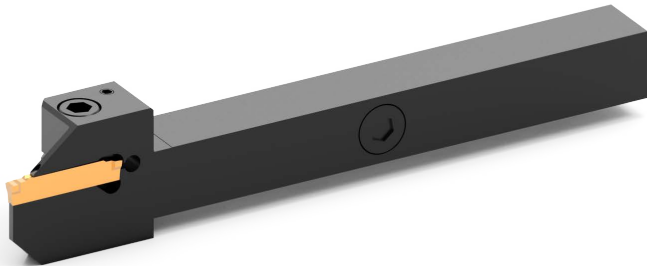
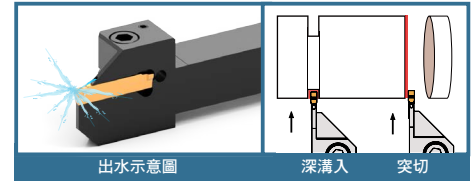

**AGNDRM1212JX-211JS**

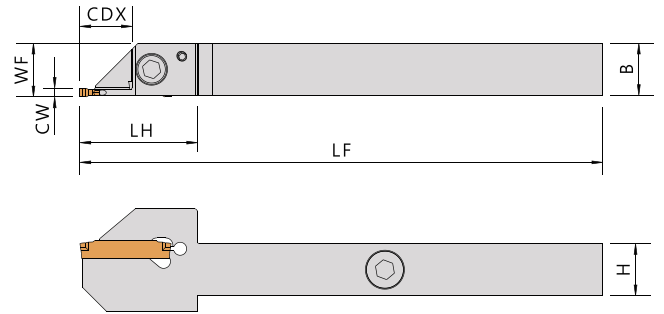

**AGNDRM2525M-525**

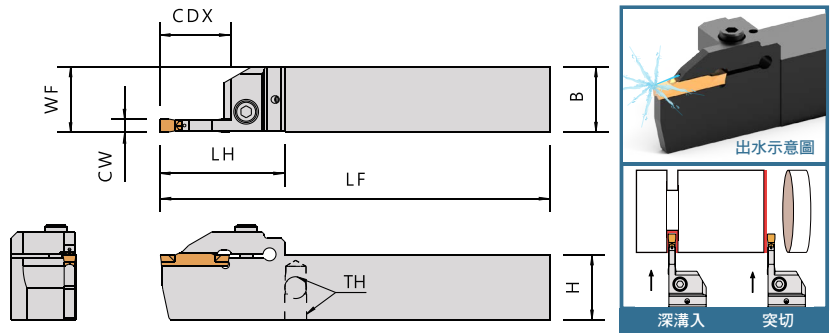

▼ Recommended Inserts 建議刀片品牌：SUMITOMO

Order No.	Insert	Dimensions(mm)								Parts			Wrench
		柄高	柄寬	總長	寬度	頭長	切寬	切深	牙孔	刀片螺絲	止付螺絲	板手	
Right / Left		H	B	LF	WF	LH	CW	CDX	Th				
AGNDRM1212JX-211JS	GCMN20	12	12	120	12.35	27	2	11	5/16"	CSH0412	CS9NN CS9-2002	LW030 LW040	
AGNDRM1212JX-218JS	GCMN20	12	12	120	12.35	33	2	18	5/16"				
AGNDRM2525M-320	GCMN30	25	25	150	25.25	44.5	3	20	1/8"	CSH0514	CS9NQ CS9-3003	LW040	
AGNDRM2525M-525	GCMN50	25	25	150	25.25	48	5	25	1/8"				

- Direct coolant supply through the turning tool.
- Shorten processing time by high cutting speed.
- 30 to 150% longer tool life for different kind of materials.
- Improved chip breaking, particularly at pressures above 40 bar.

# Grooving Tools 槽刀

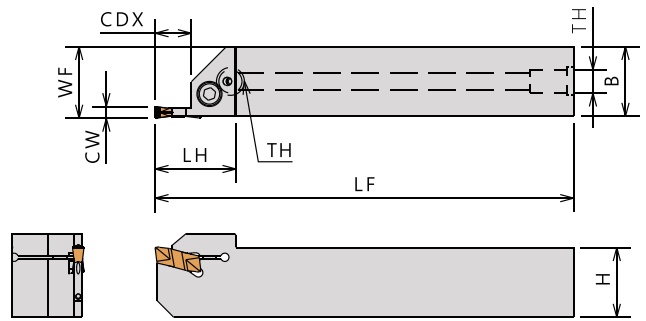
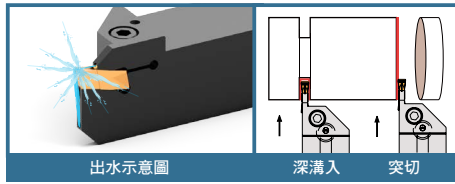

## ▼ Recommended Inserts 建議刀片品牌：ISCAR

Order No.	Insert	Dimensions(mm)									Parts				Wrench
		柄高	柄寬	總長	寬度	頭長	切寬	切深	下巴厚	牙孔	刀片螺絲	止付螺絲	轉接頭	板手	
Right / Left		H	B	LF	WF	LH	CW	CDX	HBH	Th					
AGHSR1212JX03-10R	GIP 3.00-020	12	12	120	12.6	27	3	10	2	5/16"	CSH0512	CS9NN CS9-3003	CS9NP	LW040	
AGHSR1616JX03-10R		16	16	120	16.6	26	3	10	2	1/8"		CS9NQ CS9-3003			
AGHSR2020K03-10		20	20	125	20.6	27	3	10	-	1/8"		CS9NQ CS9-3003			
AGHSR2525M03-12JS		25	25	150	25.6	29	3	12	-	1/8"	CS9NQ CS9-3003	-			
AGHSR2525M04-12JSWP	GIP 4.00	25	25	150	25.6	29	4	12	-	1/8"	CSH0516	CS9NQ CS9-2002 CS9-3003			

WP : Multiple coolant direction 上下雙出水

- Direct coolant supply through the turning tool.
- Shorten processing time by high cutting speed.
- 30 to 150% longer tool life for different kind of materials.
- Improved chip breaking, particularly at pressures above 40 bar.

# Grooving Tools 槽刀

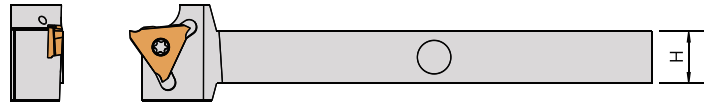
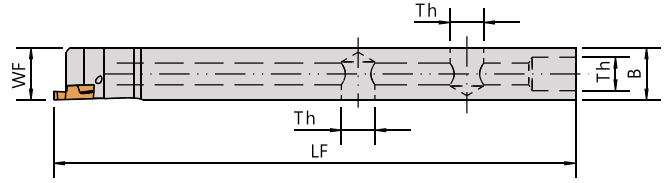
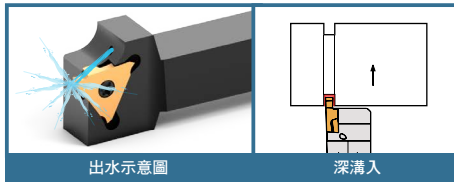

▼ Recommended Inserts 建議刀片品牌 : SUMITOMO / ACC

Without coolant thru 無油孔-TGWCR Series 系列

Order No.	Insert	Dimensions(mm)					Parts			Wrench	
		柄高 H	柄寬 B	總長 LF	寬度 WF	牙孔 Th	刀片螺絲	止付螺絲	轉接頭	板手	
AGWCR1212-3	TGAR3 TGR16	12	12	120	12	5/16"	CS40090	CSPNN CS9-3003	CS9NP	TL-15	LW040
AGWCR1616-3		16	16	120	16	1/8"		CS9NQ CS9-3003	-	TL-15	LW040

- Direct coolant supply through the turning tool.
- Shorten processing time by high cutting speed.
- 30 to 150% longer tool life for different kind of materials.
- Improved chip breaking, particularly at pressures above 40 bar.

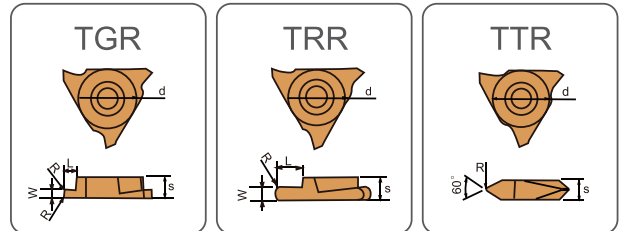
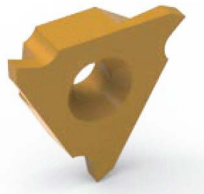

Ordering Code	UA3F2	W	L	R	d	S
TGR16050	*	0.50	1.4	0.00	9.525	3.18
TGR16075	*	0.75	2.5	0.10	9.525	3.18
TGR16095	*	0.95	2.5	0.10	9.525	3.18
TGR16100	*	1.00	2.5	0.10	9.525	3.18
TGR16125	*	1.25	2.5	0.10	9.525	3.18
TGR16135	*	1.35	2.5	0.10	9.525	3.18
TGR16150	*	1.50	2.5	0.20	9.525	3.18
TGR16200	*	2.00	3.0	0.20	9.525	3.18
TGR22100	*	1.00	2.5	0.10	12.70	4.76
TGR22125	*	1.25	2.5	0.20	12.70	4.76
TGR22135	*	1.35	2.5	0.20	12.70	4.76
TGR22145	*	1.45	2.5	0.20	12.70	4.76
TGR22150	*	1.50	3.9	0.20	12.70	4.76
TGR22200	*	2.00	3.9	0.20	12.70	4.76
TGR22250	*	2.50	5.4	0.30	12.70	4.76
TGR22300	*	3.00	5.4	0.30	12.70	4.76

Ordering Code	UA3F2	W	L	R	d	S
TRR22050	*	1.00	2.5	0.50	12.70	4.76
TRR22075	*	1.50	3.9	0.75	12.70	4.76
TRR22100	*	2.00	3.9	1.00	12.70	4.76
TRR22125	*	2.50	5.4	1.25	12.70	4.76
TRR22150	*	3.00	5.4	1.50	12.70	4.76
TRR22175	*	3.50	5.4	1.75	12.70	4.76
TRR22200	*	4.00	5.4	2.00	12.70	4.76

Ordering Code	UA3F2	Pitch (mm)	R	d	S
TTR226001	*	1.0~1.75	0.10	12.70	4.76
TTR226002	*	2.0~2.5	0.20	12.70	4.76

# Grooving Tools 槽刀

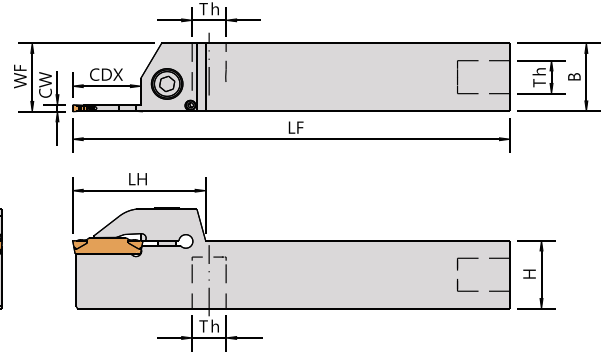
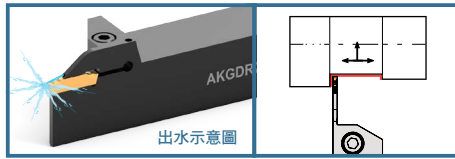

▼ Recommended Inserts 建議刀片品牌：KYOCERA

Order No.	Insert	Dimensions(mm)									Parts				Wrench
		柄高	柄寬	總長	寬度	頭長	切寬	切深	下巴厚	牙孔	刀片螺絲	止付螺絲	轉接頭	板手	
Right / Left		H	B	LF	WF	LH	CW	CDX	HBH	Th					
AKGDR1212H-2T13	GDM20	12	12	100	12.15	24	2	13	2	5/16"	CSB0414	CS9NN CS9-2002 CS9-5005	CS9NP	FT-15 LW025 LW040	
AKGDR/L1212JX-2T12JF		12	12	120	12.15	24	2	12	2	5/16"	CSR50140	CS9NN CS9-2002 CS9-5005	-	FT-15 LW040	
AKGDL1212JX-2T13JF		12	12	120	12.15	25	2	13	2	5/16"	CSR50140	CS9NN CS9-2002 CS9-5005	-	FT-15 LW040	
AKGDR1212K-2T18		12	12	125	12.15	30	2	18	2	5/16"	CSB0414	CS9NN CS9-2002 CS9-5005	CS9NP	LW025 LW040	
AKGDR1616H-2T13		16	16	100	16.15	33	2	13	4	1/8"	CSH0514	CS9NQ CS9-3003	-	LW040	
AKGDR/L1616JX-2T17JF		16	16	120	16.15	29	2	17	-	1/8"	CSR50140	CS9NQ CS9-2002 CS9-6006	-	FT-15 LW040	
AKGDR1616K-2T18		16	16	125	16.15	36	2	18	4	1/8"	CSH0514	CS9NQ CS9-3003	-	LW040	
AKGDR/L2020K-2T18S		20	20	125	20.15	38	2	18	-	1/8"	CSH0520	CS9NQ CS9-25025	-	LW040	
AKGDR2525M-2T18S		25	25	150	25.15	38	2	18	-	1/8"	CSH0520	CS9NQ CS9-25025	-		
AKGDR1212K-3T18		GDM30	12	12	125	12.3	30	3	18	2	5/16"	CSH0520	CS9NN CS9-3003	CS9NP	LW040
AKGDR1616K-3T18	16		16	125	16.3	36	3	18	4	1/8"	CSH0520	CS9NQ CS9-3003	-	LW040	
AKGDR2020K-3T18	20		20	125	20.3	38	3	18	-	1/8"	CSH0520	CS9NQ CS9-3003	-	LW040	
AKGDR2525M-3T13	25		25	150	25.3	33	3	13	-	1/8"	CSH0520	CS9NQ CS9-3003	-	LW040	
AKGDR2525M-3T20	25		25	150	25.3	38	3	20	-	1/8"		CS9NQ CS9-3003	-		

- Direct coolant supply through the turning tool.
- Shorten processing time by high cutting speed.
- 30 to 150% longer tool life for different kind of materials.
- Improved chip breaking, particularly at pressures above 40 bar.

# Grooving Tools 槽刀

ASLAL-38

ACC

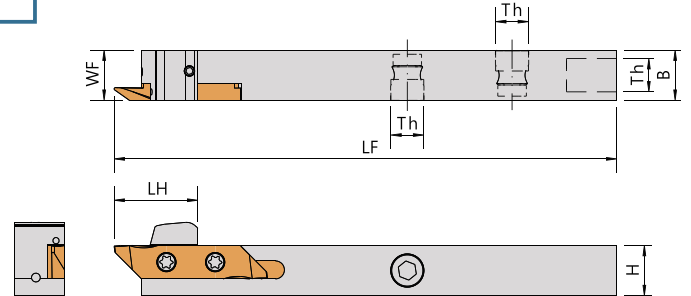
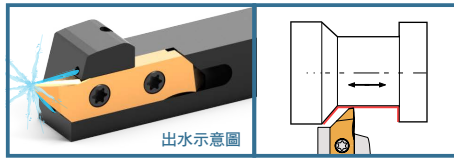

▼ Recommended Inserts 建議刀片品牌：ACC

Order No.	Insert	Dimensions(mm)						Parts			Wrench	
		柄高	柄寬	總長	寬度	頭長	牙孔	刀片螺絲	止付螺絲	轉接頭	板手	
Right / Left		H	B	LF	WF	LH	Th					
ASLALR1010JX38	L*R/L38	10	10	120	10	20	5/16"	CS35119S	CS9NN CS9-25025	CS9NP	FT-15	LW040
ASLALR1212JX38		12	12	120	12	20	5/16"					
ASLALR1616JX38		16	16	120	16	20	1/8"					

- Direct coolant supply through the turning tool.
- Shorten processing time by high cutting speed.
- 30 to 150% longer tool life for different kind of materials.
- Improved chip breaking, particularly at pressures above 40 bar.

L#R

槽刀片

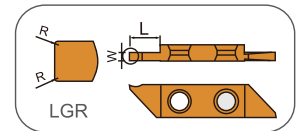
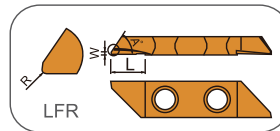
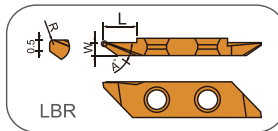

Ordering Code	UN212	W	A°	R	L
LBR382020V	*	2.0	35°	0.2	3.5
LBR383020V	*	3.0	35°	0.2	6.0
LBR384020V	*	4.0	35°	0.2	9.0

Ordering Code	UN212	W	A°	R	L
LFR383500V	*	0.5	35°	0.0	6.5
LFR383502V	*	0.5	35°	0.2	6.5
LFR385500V	*	0.5	55°	0.0	6.5
LFR385502V	*	0.5	55°	0.2	6.5

Ordering Code	UN212	W	R	L
LGR381000U	*	1.0	0.0	2.5
LGR381500U	*	1.5	0.0	5.0
LGR382020U	*	2.0	0.2	6.0
LGR382520U	*	2.5	0.2	8.0
LGR383020U	*	3.0	0.2	8.0



# Grooving Tools 槽刀

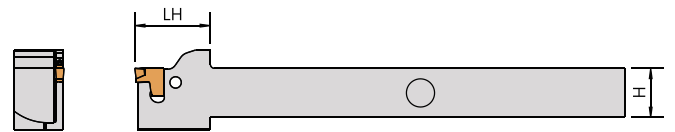
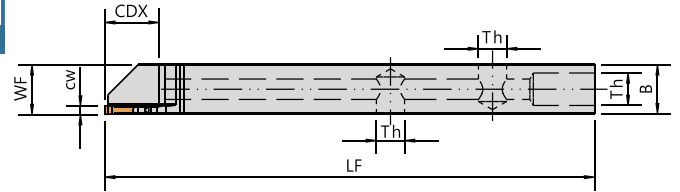
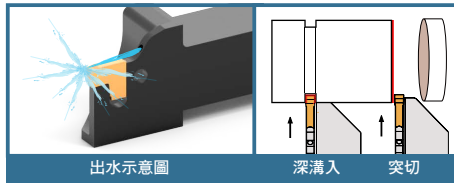

## ▼ Recommended Inserts 建議刀片品牌：ISCAR

Order No.	Insert	Dimensions(mm)								Parts			Wrench
		柄高	柄寬	總長	寬度	頭長	刀寬	切深	牙孔	刀片螺絲	止付螺絲	轉接頭	板手
Right / Left		H	B	LF	WF	LH	CW	CDX	Th				
ATGTR1212-2J24	TAG-N2J	12	12	110	12.2	18.5	2	12	5/16"	-	CS9NN CS9-3003	CS9NP	LW040

- Direct coolant supply through the turning tool.
- Shorten processing time by high cutting speed.
- 30 to 150% longer tool life for different kind of materials.
- Improved chip breaking, particularly at pressures above 40 bar.

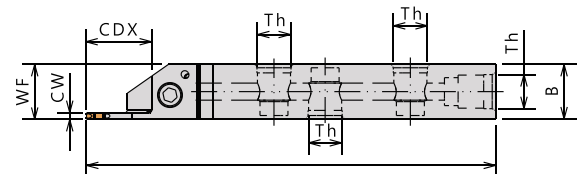
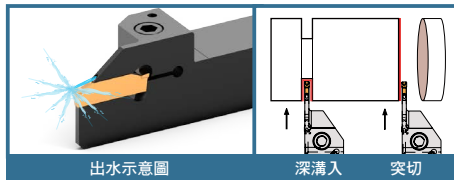

## ▼ Recommended Inserts 建議刀片品牌：ACHTECK

Order No.	Insert	Dimensions(mm)										Parts			Wrench
		柄高	柄寬	總長	寬度	頭長	切寬	切深	下巴厚	牙孔	刀片螺絲	止付螺絲	轉接頭	板手	
Right / Left		H	B	LF	WF	LH	CW	CDX	HBH	Th					
ATSER/L12B-2D24JS	ACD202	12	12	120	12.15	33	2	12	3.5	5/16"	CSH0412	CS9NN CS9-2002	CS9NP	LW030 LW040	
ATSER/L12B-2D36JS		12	12	120	12.15	33	2	18	3.5	5/16"					CS9NN CS9-2002
ATSER/L16B-2D26JS		16	16	120	16.15	33	2	13	-	1/8"		CS9NQ CS9-2002			
ATSER/L16B-2D36JS		16	16	120	16.15	33	2	18	-	1/8"		-			

- Direct coolant supply through the turning tool.
- Shorten processing time by high cutting speed.
- 30 to 150% longer tool life for different kind of materials.
- Improved chip breaking, particularly at pressures above 40 bar.

# Grooving Tools 槽刀

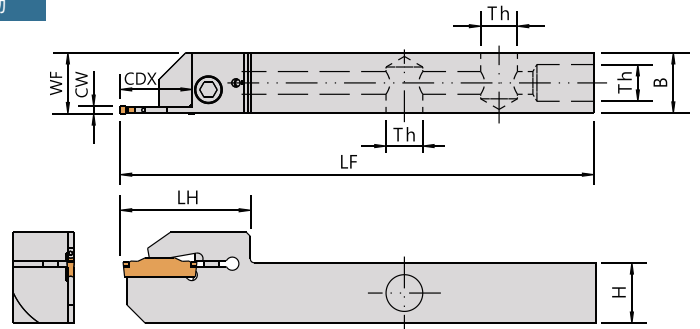
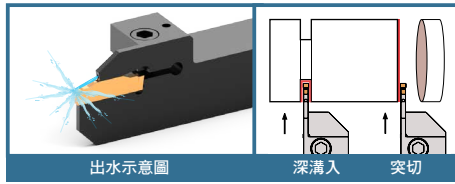

## ▼ Recommended Inserts 建議刀片品牌 : TaeguTec

Order No.	Insert	Dimensions(mm)								Parts				Wrench
		柄高	柄寬	總長	寬度	頭長	切寬	切深	牙孔	刀片螺絲	止付螺絲	轉接頭	板手	
Right / Left		H	B	LF	WF	LH	CW	CDX	Th					
ATTER/L12B-2D36JS	TDJ2	12	12	125	12.2	33.6	2	18	5/16"	CSH0414	CS9NN CS9-2002	CS9NP	LW030 LW040	
ATTER/L16B-2D36JS		16	16	125	16.2	33.6	2	18	1/8"	CSH0414	CS9NQ CS9-2002	-		

- Direct coolant supply through the turning tool.
- Shorten processing time by high cutting speed.
- 30 to 150% longer tool life for different kind of materials.
- Improved chip breaking, particularly at pressures above 40 bar.

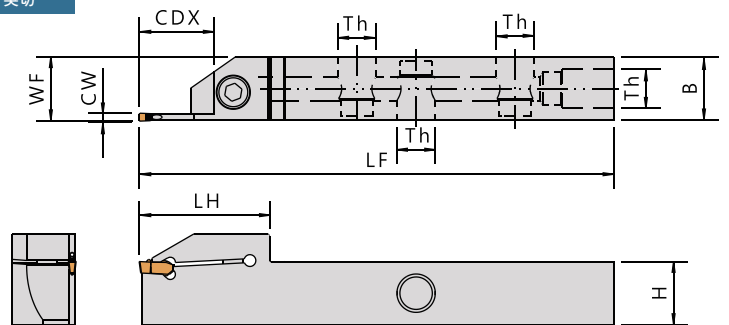
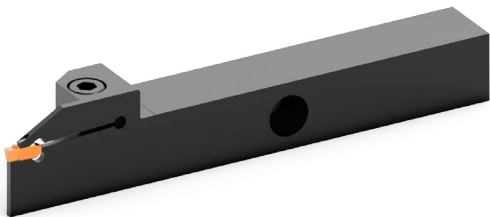
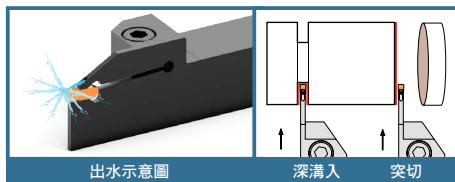

## ▼ Recommended Inserts 建議刀片品牌 : WIDIA

Order No.	Insert	Dimensions(mm)								Parts			Wrench
		柄高	柄寬	總長	寬度	頭長	切寬	切深	牙孔	刀片螺絲	止付螺絲	板手	
Right / Left		H	B	LF	WF	LH	CW	CDX	Th				
AWGCSMR/L16B-2D36JS	WC020M02	16	16	120	16.2	33	2	18	1/8"	CSH0516	CS9NQ CS9-3003	LW040	
AWGCSMR25B-2D36J		25	25	150	25.2	33	2	18	1/8"	CSH0516	CS9NQ		

- Direct coolant supply through the turning tool.
- Shorten processing time by high cutting speed.
- 30 to 150% longer tool life for different kind of materials.
- Improved chip breaking, particularly at pressures above 40 bar.





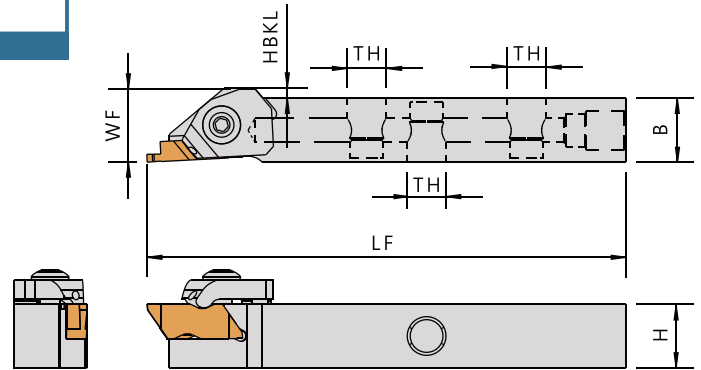
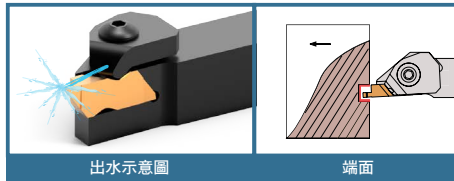

# Grooving Tools 槽刀







AUASR

ACC /  
KENNAMETAL



▼ Recommended Inserts 建議刀片品牌：KENNAMETAL / WIDIA / ACC

Order No.	Insert	Dimensions(mm)								Parts						Wrench
		柄高	柄寬	總長	頭長	切寬	切深	背面長度差	牙孔	壓板	壓板螺絲	O型環	止付螺絲	轉接頭	板手	
Right / Left		H	B	LF	LH	CW	CDX	HBKL	Th							
AUASR-1212JX2	N**R2 / NG2M	12	12	120	-	2	3.5	-	5/16"	CPK3A-A	CSH3512	WS04	CS9NN	CS9NP	LW025 LW040	
AUASR-1616JX3	N**R3 / NG3M	16	16	120	-	3	5.3	2.5	1/8"	CPK1-A	CSB0516	WS04	CS9NQ	-	LW040	

Order No.	Insert	Dimensions(mm)								Parts						Wrench
		柄高	柄寬	總長	頭長	切寬	切深	背面長度差	牙孔	壓板	壓板螺絲	O型環	止付螺絲	轉接頭	板手	
Right / Left		H	B	LF	LH	CW	CDX	HBKL	Th							
AUSR/L-2525M3	N**R3 / NG3M	25	25	150	33	3	5.3	-	1/8"	CPK1-U	CSH0516	WS04	CS9NQ	-	LW040	

- Direct coolant supply through the turning tool.
- Shorten processing time by high cutting speed.
- 30 to 150% longer tool life for different kind of materials.
- Improved chip breaking, particularly at pressures above 40 bar.

N#R

槽刀片

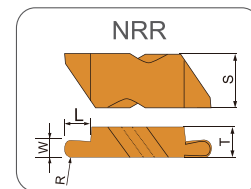
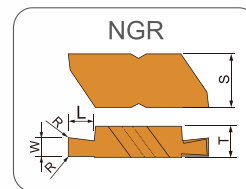
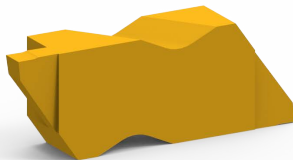

Ordering Code	UN123	W	L	R	T	S
NGR21000	*	1.00	1.3	0.0	3.81	5.56
NGR21500	*	1.50	2.8	0.0	3.81	5.56
NGR22020	*	2.00	2.8	0.2	3.81	5.56
NGR22520	*	2.50	2.8	0.2	3.81	5.56
NGR31500	*	1.50	2.4	0.0	4.95	8.74
NGR32020	*	2.00	2.4	0.2	4.95	8.74
NGR32520	*	2.50	3.8	0.2	4.95	8.74
NGR33020	*	3.00	3.8	0.2	4.95	8.74

Ordering Code	UN123	W	L	R	T	S
NRR210050	*	1.00	1.5	0.50	3.81	5.56
NRR215075	*	1.50	2.5	0.75	3.81	5.56
NRR220100	*	2.00	2.5	1.00	3.81	5.56
NRR225125	*	2.50	2.5	1.25	3.81	5.56
NRR320100	*	2.00	2.0	1.00	4.95	8.74
NRR325125	*	2.50	3.5	1.25	4.95	8.74
NRR330150	*	3.00	3.5	1.50	4.95	8.74
NRR335175	*	3.50	3.5	1.75	4.95	8.74
NRR340200	*	4.00	3.5	2.00	4.95	8.74
NRR345225	*	4.50	3.5	2.25	4.95	8.74

# Threading Tools 牙刀

ASER  
ASER-N/NA

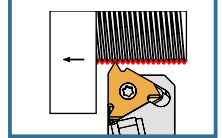
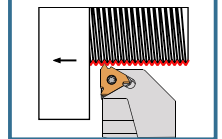
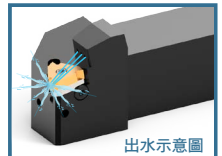
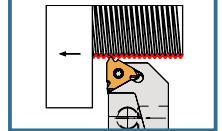
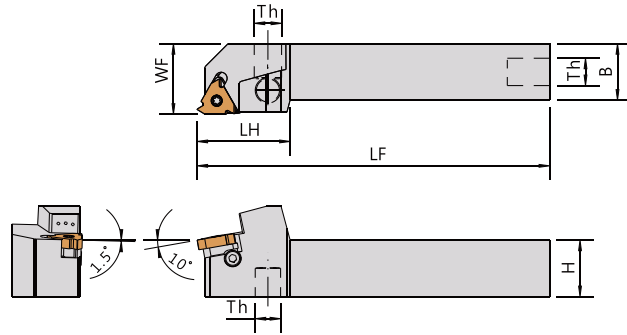
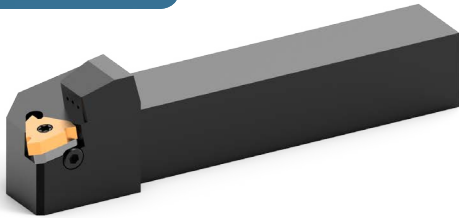

ASER-WP

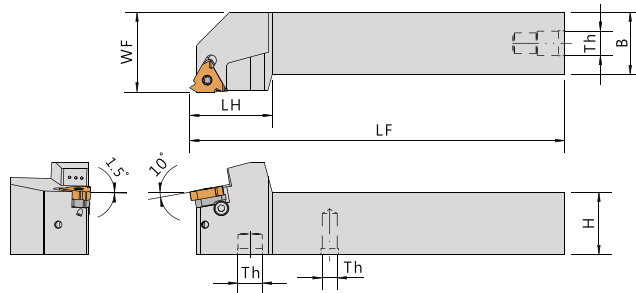
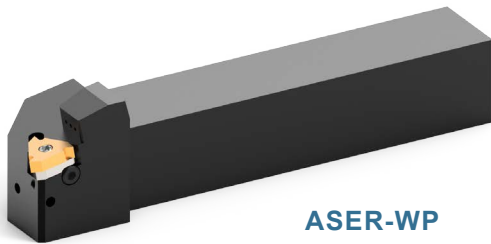

ASER-NA

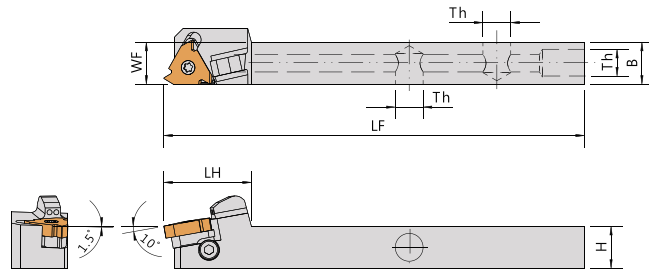

- Direct coolant supply through the turning tool.
- Shorten processing time by high cutting speed.
- 30 to 150% longer tool life for different kind of materials.
- Improved chip breaking, particularly at pressures above 40 bar.

Order No.	Insert	Dimensions(mm)						Parts				Wrench		
		柄高	柄寬	總長	頭長	寬度	牙孔	墊片		螺絲	刀片螺絲	止付螺絲	板手	
Right / Left		H	B	LF	LH	WF	Th							
ASER-2020K16A	16ER	20	20	125	33	25	1/8"	AE16	AI16	CSH0306	CS35117S	CS9NQ CS9-3003	FT-15	LW025 LW050
ASER-2525M16WP		25	25	150	33	32	1/8"							

WP : Multiple coolant direction 上下雙出水

Order No.	Insert	Dimensions(mm)						Parts				Wrench			
		柄高	柄寬	總長	頭長	寬度	牙孔	墊片		螺絲	刀片螺絲	止付螺絲	轉接頭	板手	
Right / Left		H	B	LF	LH	WF	Th								
ASER-1212JX16NA	16ER	12	12	120	25	12	5/16"	AE16	AI16	CSH0306	CS35117S	CS9NN CS9-4004	CS9NP	FT-15	LW025 LW040
ASER-1616JX16NA		16	16	120	25	12	1/8"								
ASER-2020K16NA		20	20	125	26	20	1/8"								
ASER-2525M16NA		25	25	150	26	25	1/8"								

# Boring Bar 內孔車刀

**L-SCLC-V**

95°

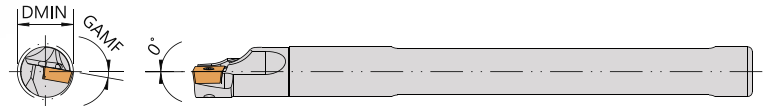
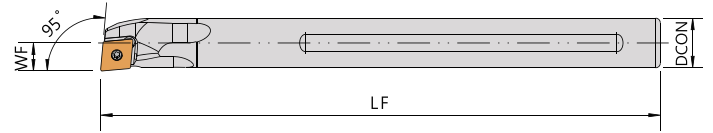
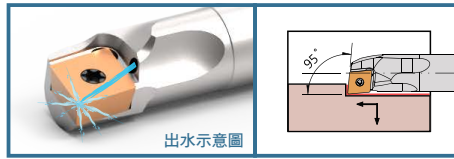

- Direct coolant supply through the turning tool.
- Shorten processing time by high cutting speed.
- 30 to 150% longer tool life for different kind of materials.
- Improved chip breaking, particularly at pressures above 40 bar.

Order No.	Insert	Dimensions(mm)						Parts	Wrench
		柄徑	工作寬度	長度	頭長	最小加工徑	徑向前角		
Right / Left		<b>DCON</b>	<b>WF</b>	<b>LF</b>	<b>LH</b>	<b>DMIN</b>	<b>GAMF</b>	刀片螺絲 	板手 
L08H-SCLCR06-10V	CCMT0602	8	5	100	20	10	14°	CS25050	FT-7
L10K-SCLCR06-12V		10	6	125	20	12	12°		
L12M-SCLCR09-14V		12	7	150	-	12	14°		
L16Q-SCLCR09-18V		16	9	180	31	18	10°		

**L-SDUC-V**

93°

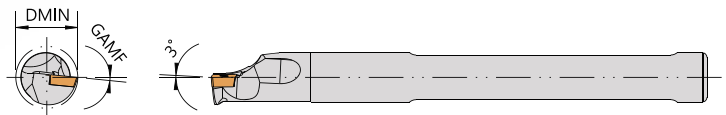
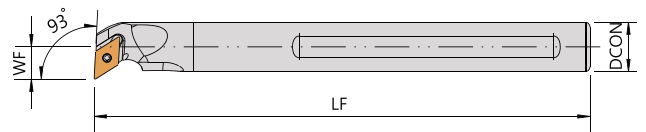
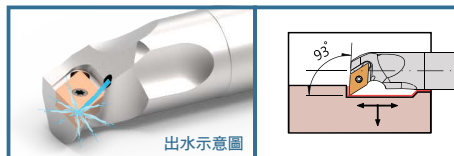

- Direct coolant supply through the turning tool.
- Shorten processing time by high cutting speed.
- 30 to 150% longer tool life for different kind of materials.
- Improved chip breaking, particularly at pressures above 40 bar.

Order No.	Insert	Dimensions(mm)						Parts	Wrench
		柄徑	工作寬度	長度	頭長	最小加工徑	徑向前角		
Right / Left		<b>DCON</b>	<b>WF</b>	<b>LF</b>	<b>LH</b>	<b>DMIN</b>	<b>GAMF</b>	刀片螺絲 	板手 
L20R-SDUCR11V	DCMT11T3	20	13	200	40	25	5.75°	CS35095	FT-15

# Boring Bar 內孔車刀

**L-STLC-V**

95°

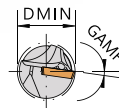
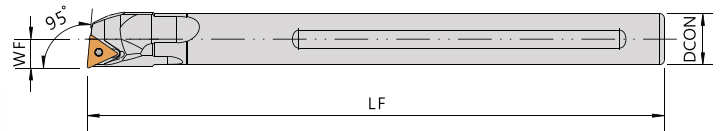
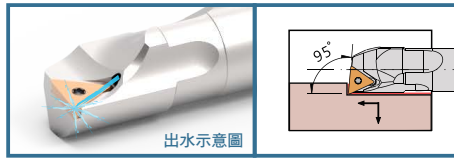

- Direct coolant supply through the turning tool.
- Shorten processing time by high cutting speed.
- 30 to 150% longer tool life for different kind of materials.
- Improved chip breaking, particularly at pressures above 40 bar.

Order No.	Insert	Dimensions(mm)						Parts	Wrench
		柄徑	工作寬度	長度	頭長	最小加工徑	徑向前角	刀片螺絲	板手
Right / Left		DCON	WF	LF	LH	DMIN	GAMF		
L08H-STLCR09-10V	TCMT0902	8	5	100	20	10	14°	CS22050	FT-7
L10K-STLCR09-12V		10	6	125	25	12	12°	CS22050	
L12M-STLCR11-14V		12	7	150	25	14	10°	CS25060	
L16Q-STLCR11-18V		16	9	180	31	18	8°	CS25060	

**L-STUP-V**

93°

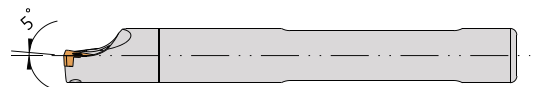
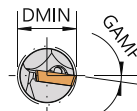
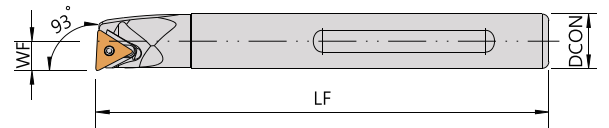
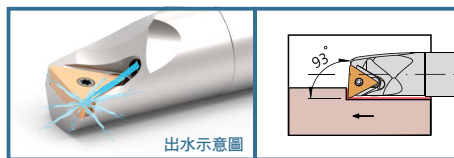

- Direct coolant supply through the turning tool.
- Shorten processing time by high cutting speed.
- 30 to 150% longer tool life for different kind of materials.
- Improved chip breaking, particularly at pressures above 40 bar.

Order No.	Insert	Dimensions(mm)						Parts	Wrench
		柄徑	工作寬度	長度	頭長	最小加工徑	徑向前角	刀片螺絲	板手
Right / Left		DCON	WF	LF	LH	DMIN	GAMF		
L12H-STUPR09-13V-L21	TPMT0902	12	6.5	100	21	13	8°	CS35095	FT-15

# Turning Tools 外徑車刀

**AACLN**

95°

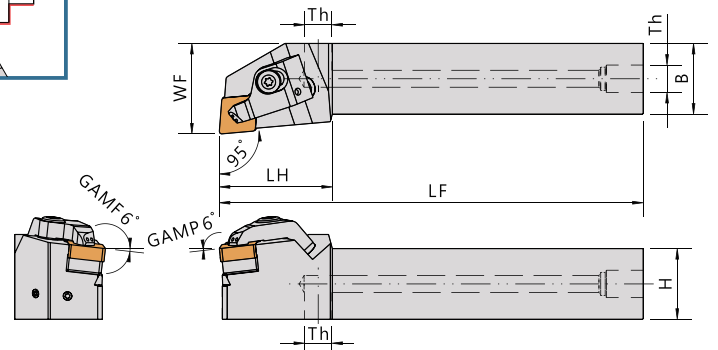
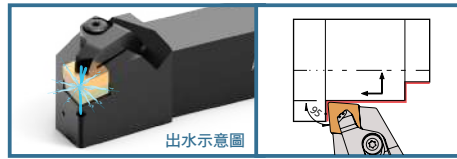

- Direct coolant supply through the turning tool.
- Shorten processing time by high cutting speed.
- 30 to 150% longer tool life for different kind of materials.
- Improved chip breaking, particularly at pressures above 40 bar.

Order No.	Insert	Dimensions(mm)						Parts								Wrench
		柄高	柄寬	總長	頭長	寬度	牙孔	墊片	墊片螺絲	壓板	壓板彈簧	壓板螺絲	C型環	止付螺絲	板手	
Right / Left		H	B	LF	LH	WF	Th									
AACLNR-2020K12WP	CNMG1204	20	20	125	40	25	1/8"	SMC-432	CSF4010	CP-AX01	SP0710	CSE5020T	ER04	CS9NQ CS9-3003	TL-20 LW025 LW040	
AACLNR-2525M12WP		25	25	150	36	32	1/8"									

WP : Multiple coolant direction 上下雙出水

**AATJN**

93°

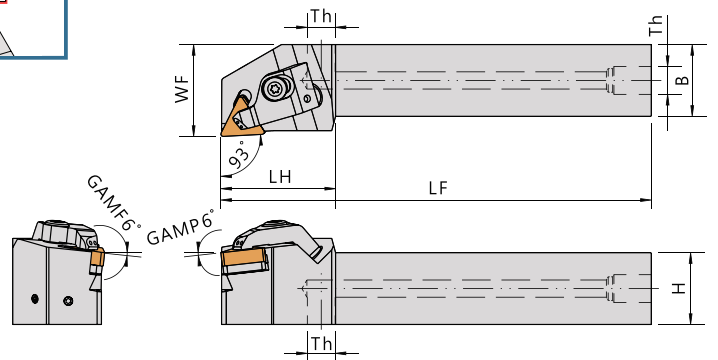
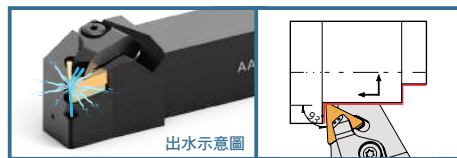

- Direct coolant supply through the turning tool.
- Shorten processing time by high cutting speed.
- 30 to 150% longer tool life for different kind of materials.
- Improved chip breaking, particularly at pressures above 40 bar.

Order No.	Insert	Dimensions(mm)						Parts								Wrench
		柄高	柄寬	總長	頭長	寬度	牙孔	墊片	墊片螺絲	壓板	壓板彈簧	壓板螺絲	C型環	止付螺絲	板手	
Right / Left		H	B	LF	LH	WF	Th									
AATJNR-2020K16WP	TNMG1604	20	20	125	40	25	1/8"	SMT-323	CS40075	CP-AX01	SP0710	CSE5020T	ER04	CS9NQ CS9-3003	TL-15 TL-20 LW040	
AATJNR-2525M16		25	25	150	40	32	1/8"									
AATJNR-2525M16WP		25	25	150	40	32	1/8"									

WP : Multiple coolant direction 上下雙出水

**AATQN**

105°

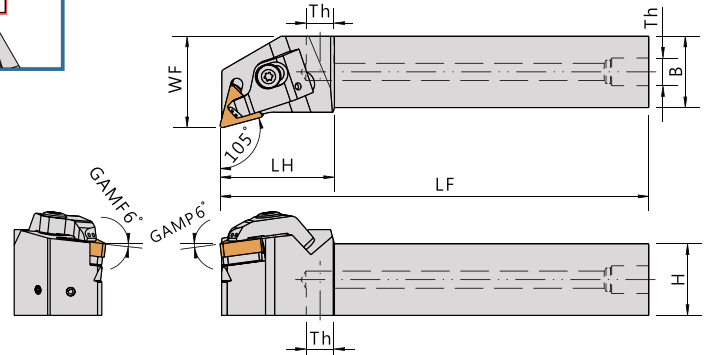
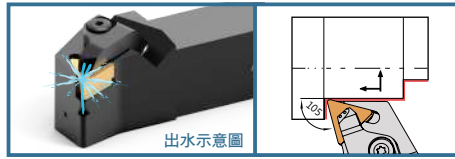

- Direct coolant supply through the turning tool.
- Shorten processing time by high cutting speed.
- 30 to 150% longer tool life for different kind of materials.
- Improved chip breaking, particularly at pressures above 40 bar.

Order No.	Insert	Dimensions(mm)						Parts								Wrench
		柄高	柄寬	總長	頭長	寬度	牙孔	墊片	墊片螺絲	壓板	壓板彈簧	壓板螺絲	C型環	止付螺絲	板手	
Right / Left		H	B	LF	LH	WF	Th									
AATQNR-2020K16WP	TNMG1604	20	20	125	40	25	1/8"	SMT-323	CSA40075	CP-AX01	SP0710	CSE5020T	ER04	CS9NQ CS9-3003	TL-15 TL-20 LW040	
AATQNR/L-2525M16WP		25	25	150	40	32	1/8"									

WP : Multiple coolant direction 上下雙出水

**AAWLN**

95°

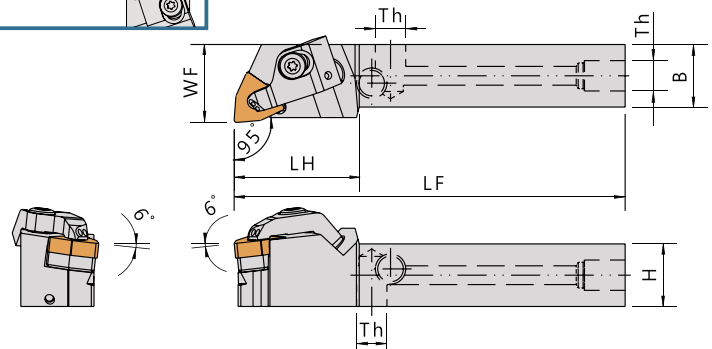

- Direct coolant supply through the turning tool.
- Shorten processing time by high cutting speed.
- 30 to 150% longer tool life for different kind of materials.
- Improved chip breaking, particularly at pressures above 40 bar.

Order No.	Insert	Dimensions(mm)						Parts								Wrench
		柄高	柄寬	總長	頭長	寬度	牙孔	墊片	墊片螺絲	壓板	壓板彈簧	壓板螺絲	C型環	止付螺絲	板手	
Right / Left		H	B	LF	LH	WF	Th									
AAWLNR-2020K08WP	WNMG0804	20	20	125	40	25	1/8"	SMW-432	CSF4010	CP-AX01	SP0710	CSE5020T	ER04	CS9NQ CS9-3003	TL-20 LW025 LW040	
AAWLNR-2525M08		25	25	150	40	32	1/8"									
AAWLNR/L-2525M08WP		25	25	150	40	32	1/8"									

WP : Multiple coolant direction 上下雙出水



**ADCLN**

95°

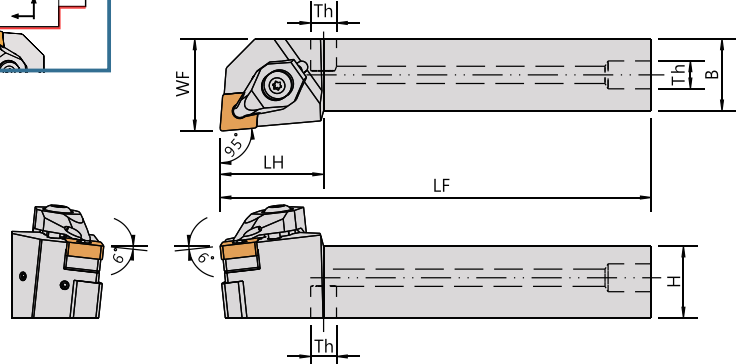
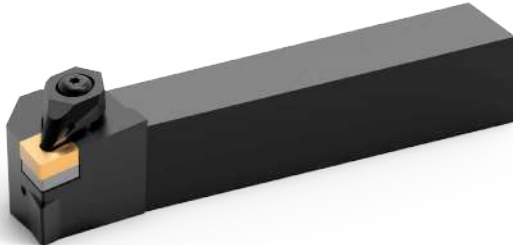
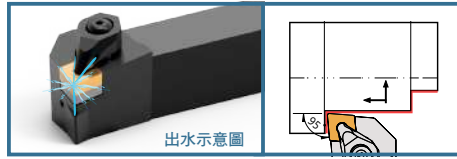

- Direct coolant supply through the turning tool.
- Shorten processing time by high cutting speed.
- 30 to 150% longer tool life for different kind of materials.
- Improved chip breaking, particularly at pressures above 40 bar.

Order No.	Insert	Dimensions(mm)						Parts								Wrench							
		柄高	柄寬	總長	頭長	寬度	牙孔	墊片	墊片螺絲	壓板	壓板彈簧	壓板螺絲	O型環	止付螺絲	板手								
Right / Left		H	B	LF	LH	WF	Th																
ADCLNR-2020K12WP	CNMG1204	20	20	125	40	25	1/8"																
ADCLNR-2525M12		25	25	150	36	32	1/8"									SMC-432	CSF4010	CP-D4AR1 CP-D4AL1	SP0816	CSB0620T	WSS3 WSA5015	CS9NQ CS9-6N CS9-3003	TL-20 LW025 LW040
ADCLNR/L-2525M12WP		25	25	150	36	32	1/8"																

WP : Multiple coolant direction 上下雙出水

**ADDJN**

93°

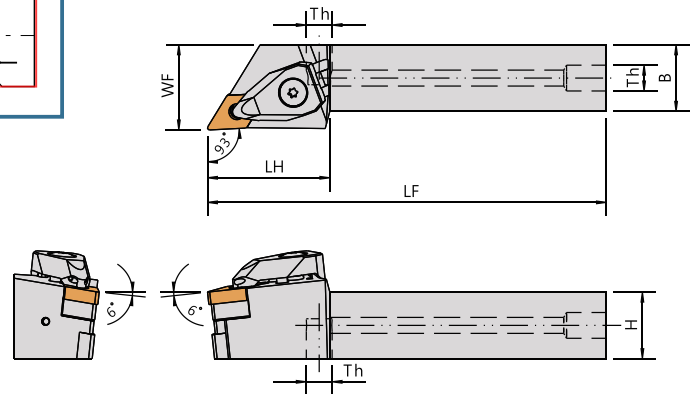
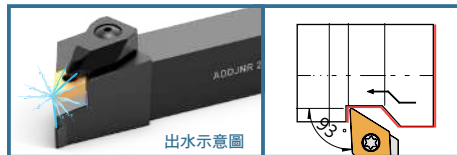

- Direct coolant supply through the turning tool.
- Shorten processing time by high cutting speed.
- 30 to 150% longer tool life for different kind of materials.
- Improved chip breaking, particularly at pressures above 40 bar.

Order No.	Insert	Dimensions(mm)						Parts								Wrench
		柄高	柄寬	總長	頭長	寬度	牙孔	墊片	墊片螺絲	壓板	壓板彈簧	壓板螺絲	C型環	O型環	止付螺絲	
Right / Left		H	B	LF	LH	WF	Th									
ADDJNL-2020K15(04/06)WP	DNMG1504 -SMD463	20	20	125	43	25	1/8"									
ADDJNR-2020M1504(04/06)		20	20	150	43	25	1/8"									
ADDJNR/L-2525M15(04/06)WP	DNMG1506 -SMD443	25	25	150	43	32	1/8"									

WP : Multiple coolant direction 上下雙出水

# Turning Tools 外徑車刀

**ADDQN**

107.5°

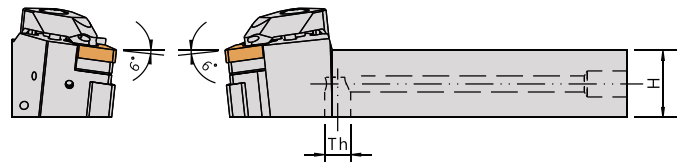
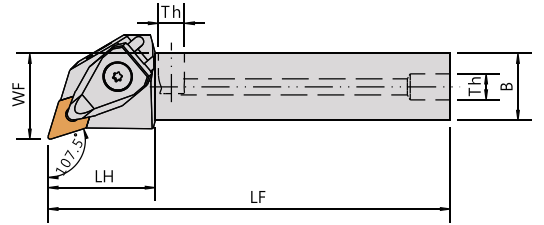
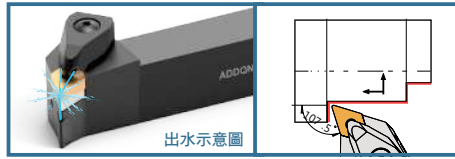

- Direct coolant supply through the turning tool.
- Shorten processing time by high cutting speed.
- 30 to 150% longer tool life for different kind of materials.
- Improved chip breaking, particularly at pressures above 40 bar.

Order No.	Insert	Dimensions(mm)						Parts								Wrench
		柄高	柄寬	總長	頭長	寬度	牙孔	墊片	墊片螺絲	壓板	壓板彈簧	壓板螺絲	C型環	O型環	止付螺絲	
Right / Left		H	B	LF	LH	WF	Th									
ADDQNR-2525M1504WP	DNMG1504	25	25	150	40	32	1/8"	SMD-463	CSF4010	CP-D3AR1	SP030	CSB0620P	ER04	WSS3 WSA5015	CS9NQ CS9-3003	TL-20 LW025 LW040

WP : Multiple coolant direction 上下雙出水

**ADTEN**

60°

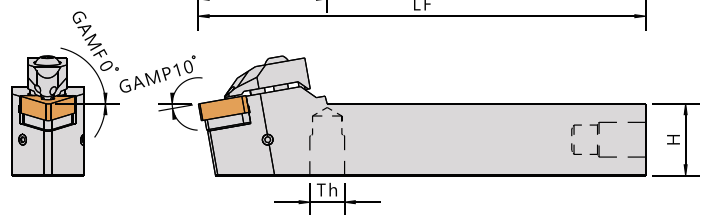
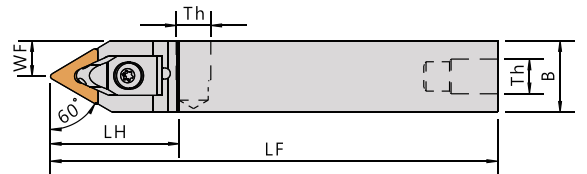
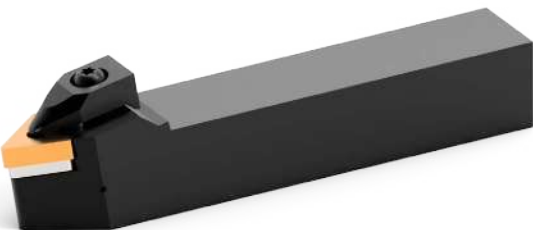
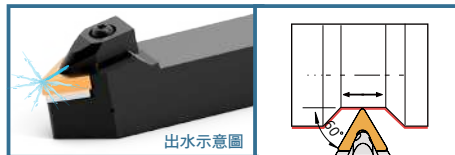

- Direct coolant supply through the turning tool.
- Shorten processing time by high cutting speed.
- 30 to 150% longer tool life for different kind of materials.
- Improved chip breaking, particularly at pressures above 40 bar.

Order No.	Insert	Dimensions(mm)						Parts								Wrench
		柄高	柄寬	總長	頭長	寬度	牙孔	墊片	墊片螺絲	壓板	壓板彈簧	壓板螺絲	O型環	止付螺絲	板手	
Right / Left		H	B	LF	LH	WF	Th									
ADTENN-1620JX16	TNMG1604	16	20	120	36	10	1/8"	SMT-323	CSA40075	CP-D2AR1	SP0612	CSB0415T	WSS3 WSA5015	CS9NQ CS9-3003	TL-15 LW015 LW040	

ADTJN

93°

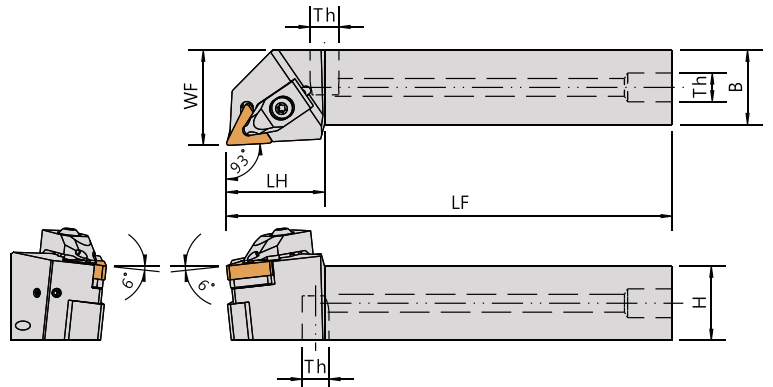
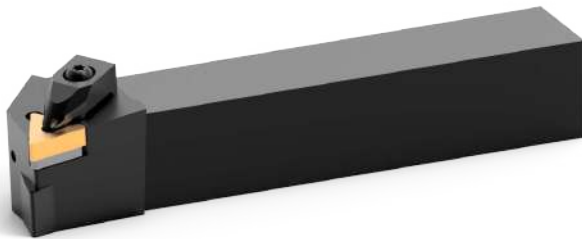

- Direct coolant supply through the turning tool.
- Shorten processing time by high cutting speed.
- 30 to 150% longer tool life for different kind of materials.
- Improved chip breaking, particularly at pressures above 40 bar.

Order No.	Insert	Dimensions(mm)						Parts								Wrench							
		柄高	柄寬	總長	頭長	寬度	牙孔	墊片	墊片螺絲	壓板	壓板彈簧	壓板螺絲	O型環	止付螺絲	轉接頭		板手						
Right / Left		H	B	LF	LH	WF	Th																
ADTJNR-1212K16N	TNMG1604	12	12	125	33	12	5/16"										CS9NN CS9-3003	CS9NP					
ADTJNR-1616K16N		16	16	125	33	16	1/8"										CS9NQ CS9-3003						
ADTJNR-2020K16WP		20	20	125	33	25	1/8"										SMT-323	CSA40075	CP-D2AR1 CP-D2AL1	SP0612	CSB0415T	WSS3 WSA5015	TL-15 LW040
ADTJNR-2525M16		25	25	150	33	32	1/8"																
ADTJNR/L-2525M16WP		25	25	150	33	32	1/8"																

WP : Multiple coolant direction 上下雙出水

# Turning Tools 外徑車刀

ADTQN

105°

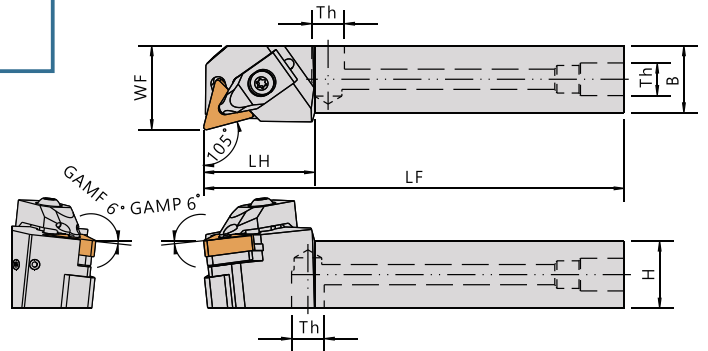
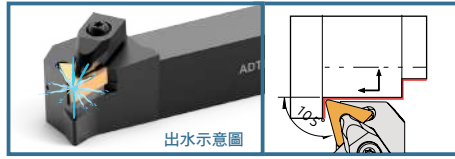

- Direct coolant supply through the turning tool.
- Shorten processing time by high cutting speed.
- 30 to 150% longer tool life for different kind of materials.
- Improved chip breaking, particularly at pressures above 40 bar.

Order No.	Insert	Dimensions(mm)						Parts								Wrench	
		柄高	柄寬	總長	頭長	寬度	牙孔	墊片	墊片螺絲	壓板	壓板彈簧	壓板螺絲	O型環	止付螺絲	板手		
Right / Left		H	B	LF	LH	WF	Th										
ADTQNR/L-2020K16WP	TNMG1604	20	20	125	25	33	1/8"	SMT-323	CSA40075	CP-D2AR1	SP0612	CSB0415T	WSS3	CSA5015	CS9NQ	CS9-3003	TL-15
ADTQNR-2525M16WP		25	25	150	32	33	1/8"			CP-D2AL1							

ADVJN

93°

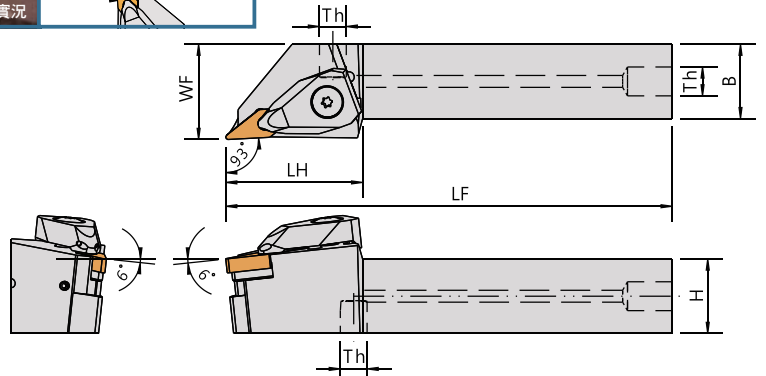

- Direct coolant supply through the turning tool.
- Shorten processing time by high cutting speed.
- 30 to 150% longer tool life for different kind of materials.
- Improved chip breaking, particularly at pressures above 40 bar.

Order No.	Insert	Dimensions(mm)						Parts								Wrench	
		柄高	柄寬	總長	頭長	寬度	牙孔	墊片	墊片螺絲	壓板	壓板彈簧	壓板螺絲	C型環	O型環	止付螺絲		板手
Right / Left		H	B	LF	LH	WF	Th										
ADVJNR/L-2020K16WP	VNMG1604	20	20	125	50	25	1/8"	SMV-322	CSA40075	CP-D3AR1	SP0816	CSB0620P	ER04	WSP25	CS9NQ	CS9-3003	TL-15
ADVJNR-2525M16WP		25	25	150	46	32	1/8"			CP-D3AL1							

WP : Multiple coolant direction 上下雙出水

# Turning Tools 外徑車刀

ADWLN

95°

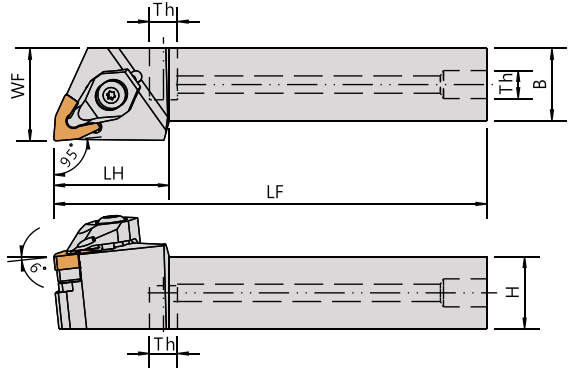
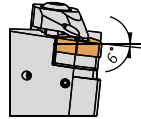
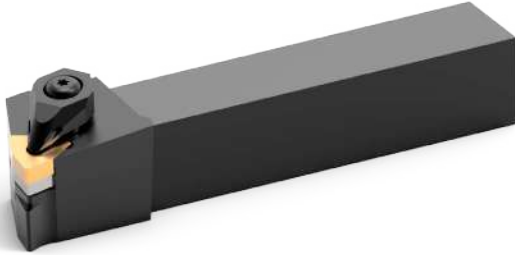
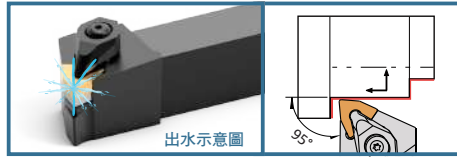

- Direct coolant supply through the turning tool.
- Shorten processing time by high cutting speed.
- 30 to 150% longer tool life for different kind of materials.
- Improved chip breaking, particularly at pressures above 40 bar.

Order No.	Insert	Dimensions(mm)						Parts							Wrench							
		柄高	柄寬	總長	頭長	寬度	牙孔	墊片	墊片螺絲	壓板	壓板彈簧	壓板螺絲	O型環	止付螺絲		板手						
Right / Left		H	B	LF	LH	WF	Th															
ADWLN-2020K08WP	WNMG080408	20	20	125	36	25	1/8"			CP-D4AR1												
ADWLN-2525M08		25	25	150	36	32	1/8"			SMW-432						CSF4010	CP-D2AR1	SP0816	CSB0620T	WSS3 WSA5015	CS9NQ CS9-3003	TL-20 LW025 LW040
ADWLN/L-2525M08WP		25	25	150	36	32	1/8"										CP-D4AR/L1					

WP : Multiple coolant direction 上下雙出水

AMCLN

95°

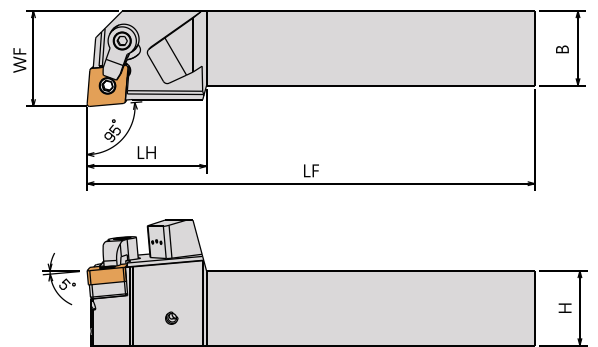
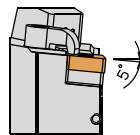
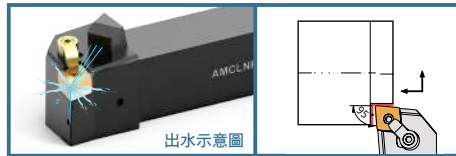

- Direct coolant supply through the turning tool.
- Shorten processing time by high cutting speed.
- 30 to 150% longer tool life for different kind of materials.
- Improved chip breaking, particularly at pressures above 40 bar.

Order No.	Insert	Dimensions(mm)						Parts					Wrench
		柄高	柄寬	總長	頭長	寬度	牙孔	墊片	墊片螺絲	壓板	壓板螺絲	止付螺絲	
Right / Left		H	B	LF	LH	WF	Th						
AMCLN-2525M12WP	CNMG1204	25	25	150	40	32	1/8"						
AMCLN-3232P12WP		32	32	170	40	40	1/8"						

WP : Multiple coolant direction 上下雙出水

AMDJN

93°

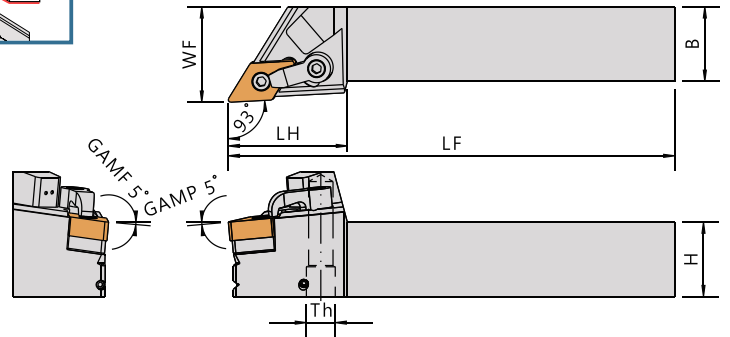
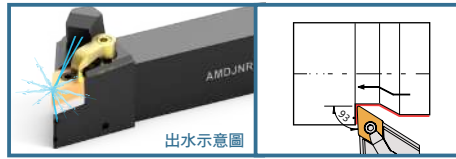

- Direct coolant supply through the turning tool.
- Shorten processing time by high cutting speed.
- 30 to 150% longer tool life for different kind of materials.
- Improved chip breaking, particularly at pressures above 40 bar.

Order No.	Insert	Dimensions(mm)							Parts					Wrench
		柄高	柄寬	總長	頭長	寬度	牙孔	墊片	墊片螺絲	壓板	壓板螺絲	止付螺絲	板手	
Right / Left		H	B	LF	LH	WF	Th							
AMDJNR-2525M15WP	DNMG1504 -SMD463 DNMG1506 -SMD443	25	25	150	40	32	1/8"	SMD4X3	LCS-619	CP50-24	CS7-6030	CS9NQ CS9-3003	LW030 LW040	

WP : Multiple coolant direction 上下雙出水

AMTJN

93°

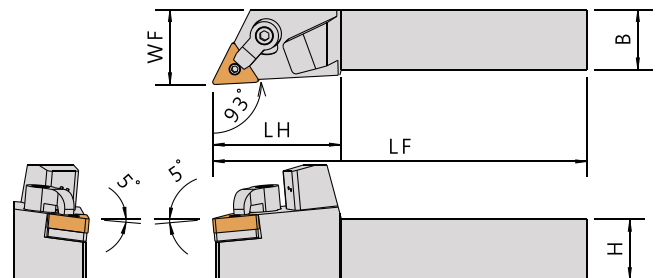
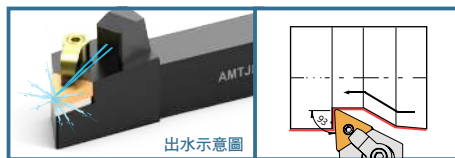

- Direct coolant supply through the turning tool.
- Shorten processing time by high cutting speed.
- 30 to 150% longer tool life for different kind of materials.
- Improved chip breaking, particularly at pressures above 40 bar.

Order No.	Insert	Dimensions(mm)							Parts					Wrench
		柄高	柄寬	總長	頭長	寬度	牙孔	墊片	墊片螺絲	壓板	壓板螺絲	止付螺絲	板手	
Right / Left		H	B	LF	LH	WF	Th							
AMTJNR-2020K16	TNMG1604	20	20	125	43	25	1/8"	SMT-322	LCS-513	CP50-22	CS7-6024	CS9NQ CS9-3003	LW020 LW030 LW040	

# Turning Tools 外徑車刀

AMVJN

93°

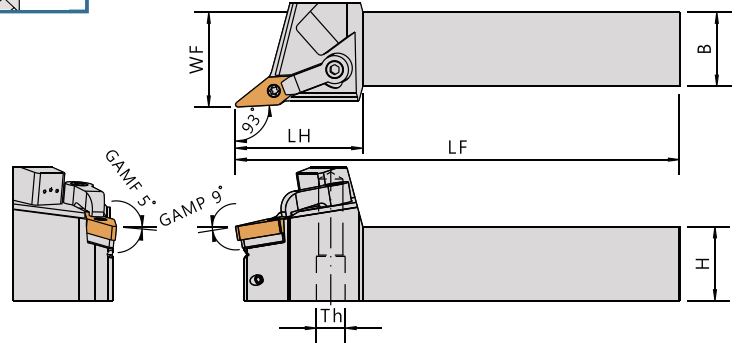
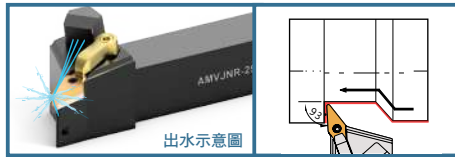

- Direct coolant supply through the turning tool.
- Shorten processing time by high cutting speed.
- 30 to 150% longer tool life for different kind of materials.
- Improved chip breaking, particularly at pressures above 40 bar.

Order No.	Insert	Dimensions(mm)						Parts					Wrench
		柄高	柄寬	總長	頭長	寬度	牙孔	墊片	墊片螺絲	壓板	壓板螺絲	止付螺絲	
Right / Left		H	B	LF	LH	WF	Th						
AMVJNR-2020K16WP	VNMG1604	20	20	125	43	25	1/8"	SMV-322	LCS-513	CP50-25	CS7-6030	CS9NQ CS9-3003	LW020 LW030 LW040
AMVJNR-2525M16WP		25	25	150	43	32	1/8"						

WP : Multiple coolant direction 上下雙出水

APCLN

95°

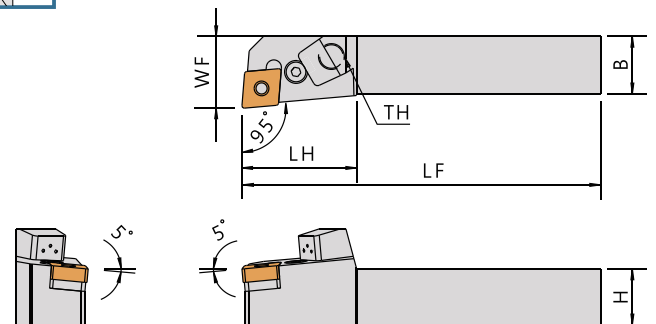
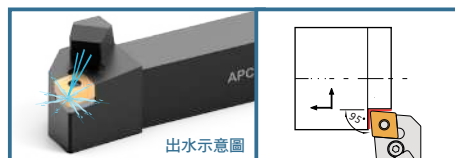

- Direct coolant supply through the turning tool.
- Shorten processing time by high cutting speed.
- 30 to 150% longer tool life for different kind of materials.
- Improved chip breaking, particularly at pressures above 40 bar.

Order No.	Insert	Dimensions(mm)						Parts					Wrench
		柄高	柄寬	總長	頭長	寬度	牙孔	墊片	墊片螺絲	壓板	壓板螺絲	止付螺絲	
Right / Left		H	B	LF	LH	WF	Th						
APCLNR-2020K12H	CNMG1204	20	20	125	40	25	1/8"	SMC-422	CS-LSP4	CP-LL4	CS-LS4	CS9NQ CS9-3003	LW030 LW040
APCLNR-2525M12		25	25	150	36	32	1/8"						
APCLNR-3232P12		32	32	170	36	40	1/8"						

**ASCLC**

95°

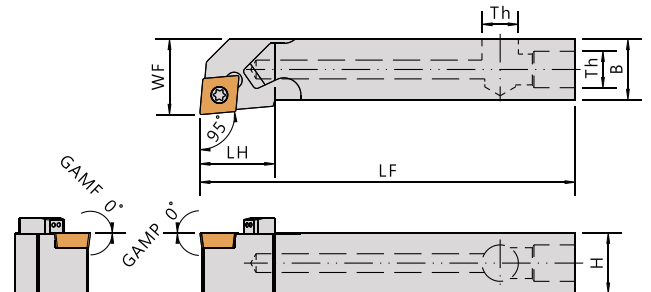
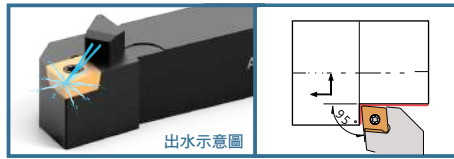

- Direct coolant supply through the turning tool.
- Shorten processing time by high cutting speed.
- 30 to 150% longer tool life for different kind of materials.
- Improved chip breaking, particularly at pressures above 40 bar.

Order No.	Insert	Dimensions(mm)						Parts				Wrench
		柄高	柄寬	總長	頭長	寬度	牙孔	刀片螺絲	止付螺絲	轉接頭	板手	
Right / Left		H	B	LF	LH	WF	Th					
ASCLCR-1212H09	CCMT09T3	12	12	100	20	16	5/16"	CS35090	CS9NN CS9-4004	-	FT-15 LW040	
ASCLCR-1616H09		16	16	100	20	20	1/8"					

**ASDNC**

62.5°

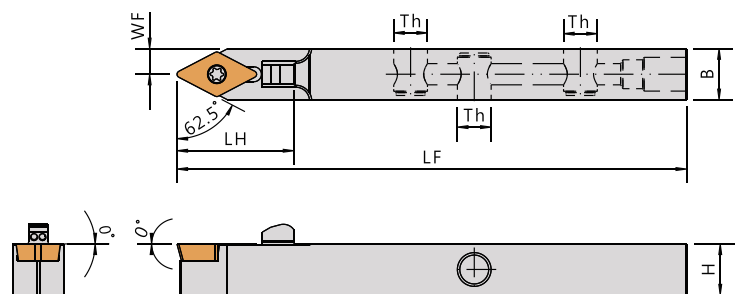
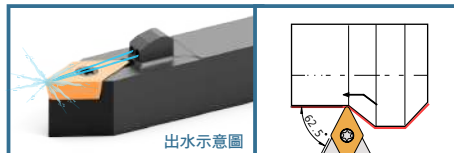

- Direct coolant supply through the turning tool.
- Shorten processing time by high cutting speed.
- 30 to 150% longer tool life for different kind of materials.
- Improved chip breaking, particularly at pressures above 40 bar.

Order No.	Insert	Dimensions(mm)						Parts				Wrench
		柄高	柄寬	總長	頭長	寬度	牙孔	刀片螺絲	止付螺絲	轉接頭	板手	
Right / Left		H	B	LF	LH	WF	Th					
ASDNCN-1212H11A	DCMT11T3	12	12	100	27.5	6	5/16"	CS35119S	CS9NN CS9-4004	CS9NP	FT-15 LW040	





ASDJC-N

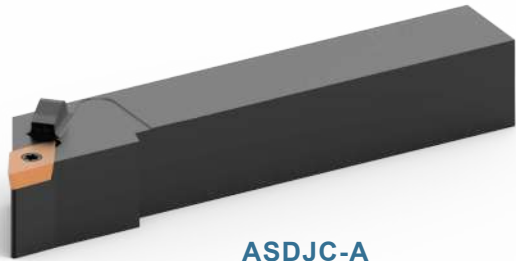
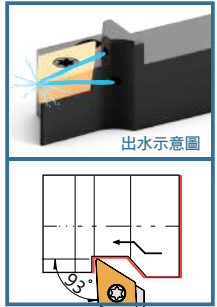
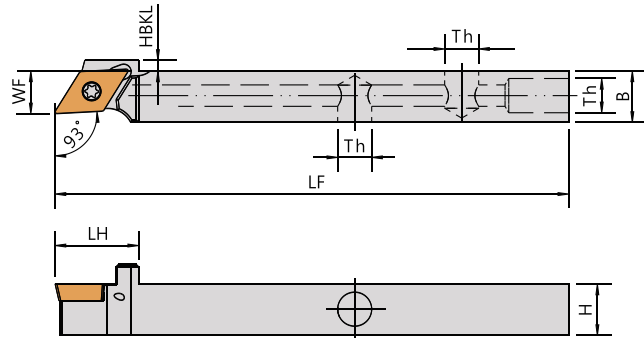

ASDJC-A

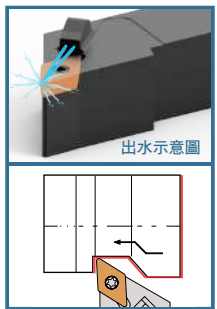
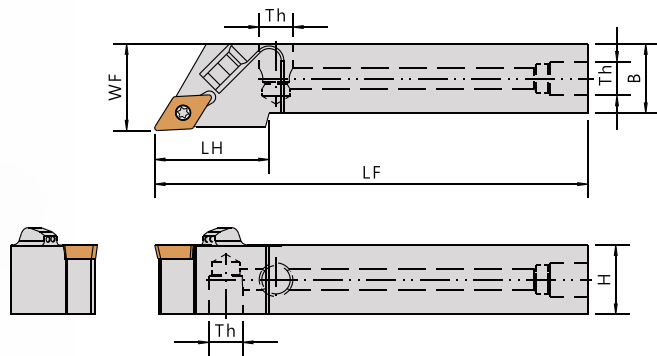

ASDJC-NA

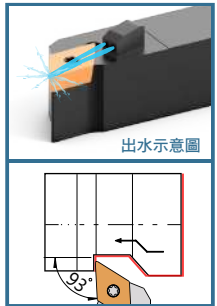
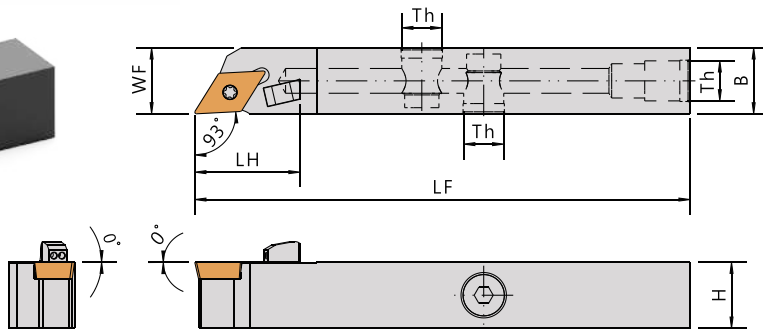

- Direct coolant supply through the turning tool.
- Shorten processing time by high cutting speed.
- 30 to 150% longer tool life for different kind of materials.
- Improved chip breaking, particularly at pressures above 40 bar.

Order No.	Insert	Dimensions(mm)							Parts			Wrench	
		柄高	柄寬	總長	頭長	寬度	背面長度差	牙孔	刀片螺絲	止付螺絲	轉接頭	板手	
Right / Left		H	B	LF	LH	WF	HBKL	Th					
ASDJCR-1212H11N	DCMT11T3	12	12	100	24	12	3	5/16"	CS35119S	CS9NN CS9-4004	CS9NP	FT-15	LW040
ASDJCR-1212H11-F10		12	12	100	19.5	10	4	5/16"		CS9NN CS9-3003			
ASDJCR/L-1212JX11NA		12	12	120	19.5	10	4	5/16"		CS9NN CS9-4004			
ASDJCR-1616H11N		16	16	100	24	16	-	1/8"	CS35095	CS9NQ CS9-4004	-	FT-15	LW040
ASDJCR-1616JX11NA		16	16	120	19.5	14	-	1/8"		CS9NQ CS9-4004			
ASDJCR-2020K11-A		20	20	125	33	25	-	1/8"	CS35119S	CS9NQ CS9-3003	-	FT-15	LW040
ASDJCR-2525M11-A		25	25	150	38	32	-	1/8"					

## ASTUP

93°

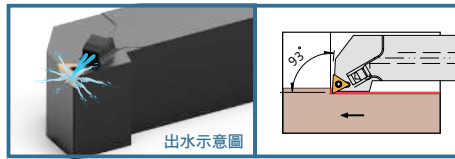

出水示意圖

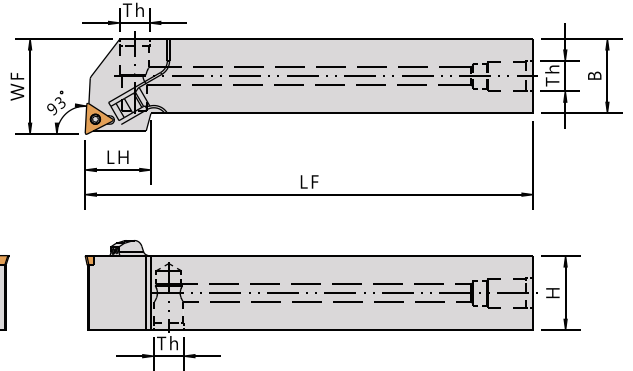

- Direct coolant supply through the turning tool.
- Shorten processing time by high cutting speed.
- 30 to 150% longer tool life for different kind of materials.
- Improved chip breaking, particularly at pressures above 40 bar.

Order No.	Insert	Dimensions(mm)						Parts			Wrench
		柄高	柄寬	總長	頭長	寬度	牙孔	刀片螺絲	止付螺絲	轉接頭	板手
Right / Left		H	B	LF	LH	WF	Th				
ASTUPR-2525M11-A	TPMT1103	25	25	150	22	32	1/8"	CSA30070	CS9NQ CS9-5005	-	FT-10 LW025 LW040

## ASVJB

93°

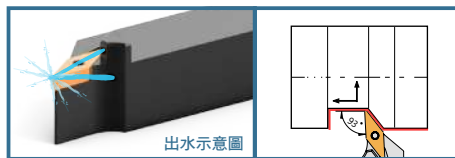

出水示意圖

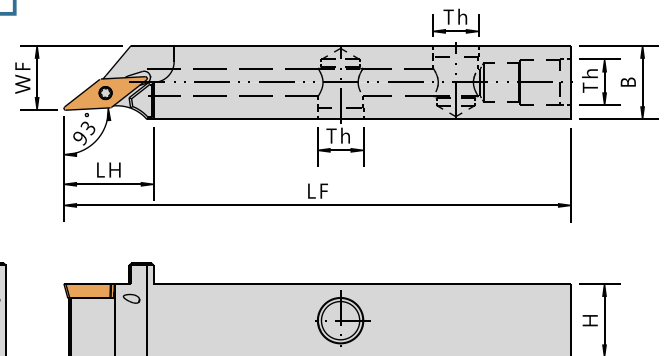

- Direct coolant supply through the turning tool.
- Shorten processing time by high cutting speed.
- 30 to 150% longer tool life for different kind of materials.
- Improved chip breaking, particularly at pressures above 40 bar.

Order No.	Insert	Dimensions(mm)						Parts			Wrench	
		柄高	柄寬	總長	頭長	寬度	牙孔	刀片螺絲	止付螺絲	轉接頭	板手	
Right / Left		H	B	LF	LH	WF	Th					
ASVJBR-1212JX11NA	VBMT1103	12	12	120	19.5	10	5/16"	CS25055PS	CS9NN CS9-4004	-	FT-7	LW040
ASVJBR-1616JX11NA		16	16	120	19.5	14	1/8"		CS9NQ CS9-5005	-	FT-7	LW050

ASVJC  
ASVJC-N/NA

93°

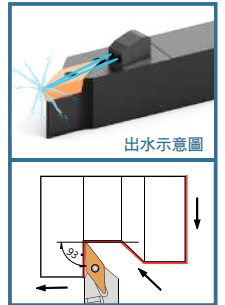
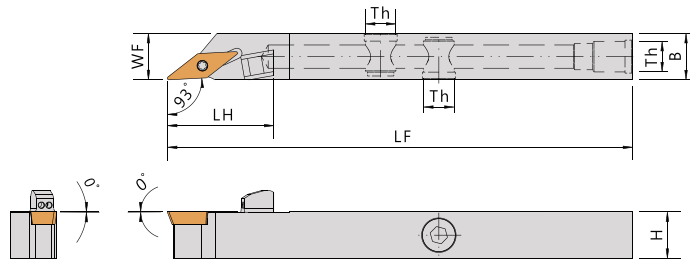
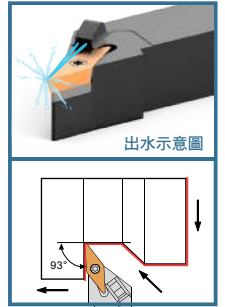
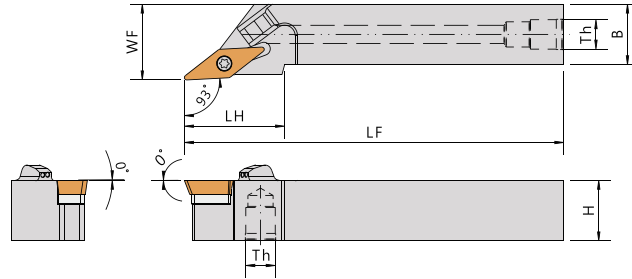
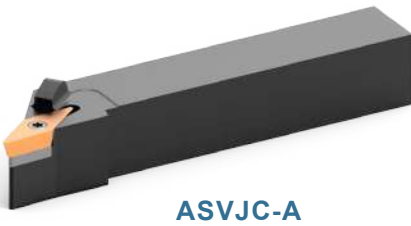
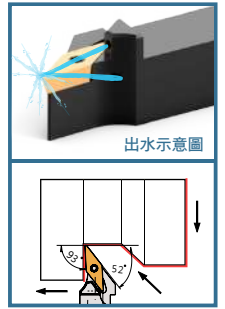
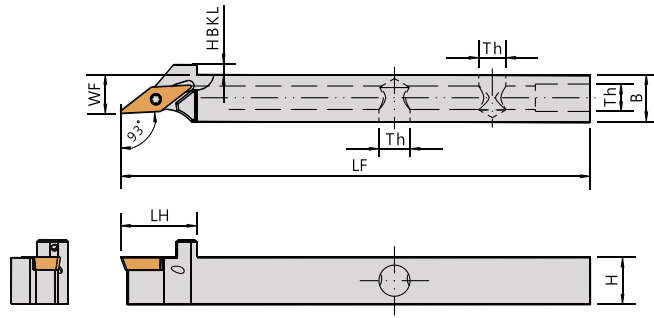

- Direct coolant supply through the turning tool.
- Shorten processing time by high cutting speed.
- 30 to 150% longer tool life for different kind of materials.
- Improved chip breaking, particularly at pressures above 40 bar.

Order No.	Insert	Dimensions(mm)							Parts					Wrench	
		柄高	柄寬	總長	頭長	寬度	背面長度差	牙孔	墊片	墊片螺絲	刀片螺絲	止付螺絲	轉接頭	板手	
Right / Left		H	B	LF	LH	WF	HBKL	Th							
ASVJCR-1010H11-F08	VCMT1103	10	10	100	19.5	8	2.5	5/16"	-	-	CS25055PS	CS9NN CS9-3003	CS9NP	FT-7	LW040
ASVJCR-1212-11NACB		12	12	140	24	12	4.5	5/16"	-	-	CS25055PS	CS9NN CS9-4004		FT-7	LW040
ASVJCR/L-1212H11-F10		12	12	100	19.5	10	2.5	5/16"	-	-	CS25055PS	CS9NN CS9-3003		FT-7	LW040
ASVJCR-1212H11N		12	12	100	27.5	12	-	5/16"	-	-	CS25060	CS9NN CS9-3003		FT-7	LW040
ASVJCR-1212JX11NA		12	12	120	27.5	12	-	5/16"	-	-	CS25060	CS9NN CS9-3003		FT-7	LW040
ASVJCR/L-1616H11-F14		16	16	100	36	14	-	1/8"	-	-	CS25060	CS9NQ CS9-3003		FT-7	LW040
ASVJCR-1616-11NACB	VCMT1604	16	16	140	27.5	16	-	1/8"	-	-	CS25060	CS9NQ CS9-3003	-	FT-7	LW040
ASVJCR/L-2020K16-A		20	20	125	33	25	-	1/8"	SMV-321	SN535	CS35117S	CS9NQ	-	FT-15	LW040
ASVJCR-2020K16-F18		20	20	125	25	18	-	1/8"	-	-	CS35117S	CS9NQ CS9-3003	-	FT-15	LW040
ASVJCR/L-2525M16-A		25	25	150	33	32	-	1/8"	SMV-321	SN535	CS35117S	CS9NQ	-	FT-15	LW040

ASVJP

93°

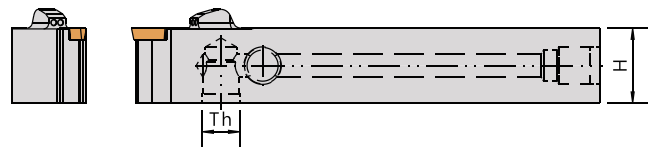
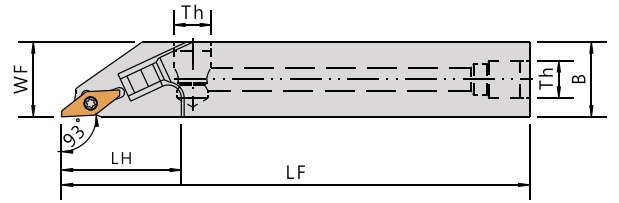
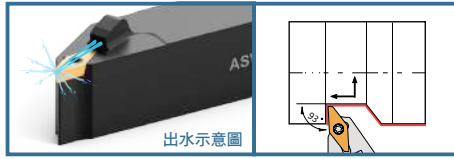

- Direct coolant supply through the turning tool.
- Shorten processing time by high cutting speed.
- 30 to 150% longer tool life for different kind of materials.
- Improved chip breaking, particularly at pressures above 40 bar.

Order No.	Insert	Dimensions(mm)						Parts				Wrench	
		柄高	柄寬	總長	頭長	寬度	牙孔	刀片螺絲	止付螺絲	轉接頭	板手		
Right / Left		H	B	LF	LH	WF	Th						
ASVJPR-1010JX10	VPGT1003	10	10	120	30	10	5/16"	CS25060	CS9NN CS9-4004	CS9NP	FT-7	LW040	
ASVJPR-1212JX10		12	12	120	30	12	5/16"						
ASVJPR-1616JX10		16	16	120	32	16	1/8"		CS9NQ CS9-4004	-	FT-7	LW040	
ASVJPR-2020K10		20	20	125	32	20	1/8"		CS9NQ	-	FT-7	LW040	

ASVKB

54.5°

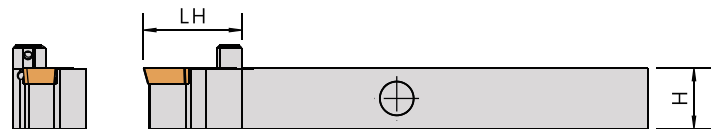
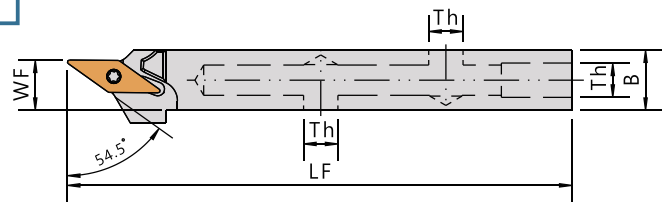
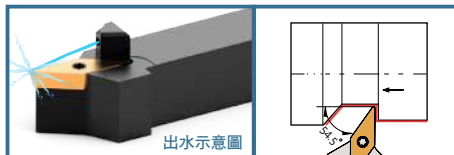

- Direct coolant supply through the turning tool.
- Shorten processing time by high cutting speed.
- 30 to 150% longer tool life for different kind of materials.
- Improved chip breaking, particularly at pressures above 40 bar.

Order No.	Insert	Dimensions(mm)						Parts			Wrench	
		柄高	柄寬	總長	頭長	寬度	牙孔	刀片螺絲	止付螺絲	轉接頭	板手	
Right / Left		H	B	LF	LH	WF	Th					
ASVKBR-1212JX11-F10	VBMT1103	12	12	120	19.5	10	5/16"	CS25055PS	CS9NN CS9-3003	CS9NP	FT-7	LW040

# Turning Tools 外徑車刀

ASVKC

90.5°

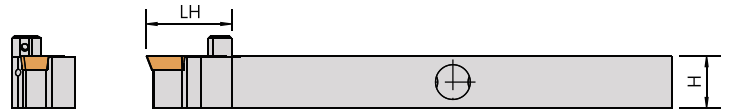
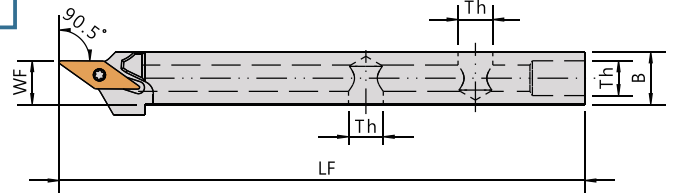
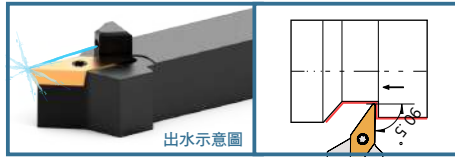

- Direct coolant supply through the turning tool.
- Shorten processing time by high cutting speed.
- 30 to 150% longer tool life for different kind of materials.
- Improved chip breaking, particularly at pressures above 40 bar.

Order No.	Insert	Dimensions(mm)						Parts			Wrench		
		柄高	柄寬	總長	頭長	寬度	牙孔	刀片螺絲	止付螺絲	轉接頭	扳手		
Right / Left		H	B	LF	LH	WF	Th						
ASVKCR-1212H11	VCMT1103	12	12	100	19.5	10	5/16"	CS25055PS		CS9NN CS9-3003	CS9NP	FT-7	LW040
ASVKCR-1212JX11-F10		12	12	120	19.5	10	5/16"						
ASVKCR/L-1616JX11		16	16	120	19.5	9	1/8"				CS9NQ CS9-3003	-	FT-7

ATJNR

93°

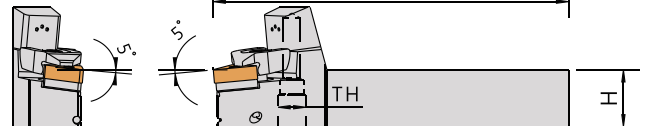
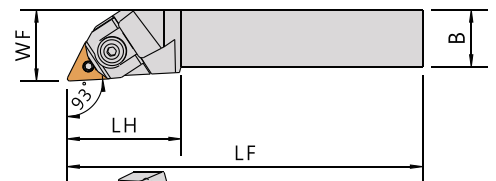
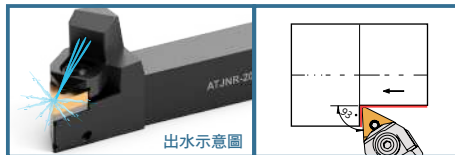

- Direct coolant supply through the turning tool.
- Shorten processing time by high cutting speed.
- 30 to 150% longer tool life for different kind of materials.
- Improved chip breaking, particularly at pressures above 40 bar.

Order No.	Insert	Dimensions(mm)						Parts						Wrench	
		柄高	柄寬	總長	頭長	寬度	牙孔	墊片	螺絲	壓板	壓板螺絲	C型環	O型環		止付螺絲
Right / Left		H	B	LF	LH	WF	Th								
ATJNR-3232P16WP	TNMG1604	32	32	170	40	40	1/8"	SMT-322	LCS-513	MTW-30	CSE5026	ER04	WS06	CS9-3003 CS9NQ	LW025 LW030 LW040

WP : Multiple coolant direction 上下雙出水

**AWLNR**  
95°

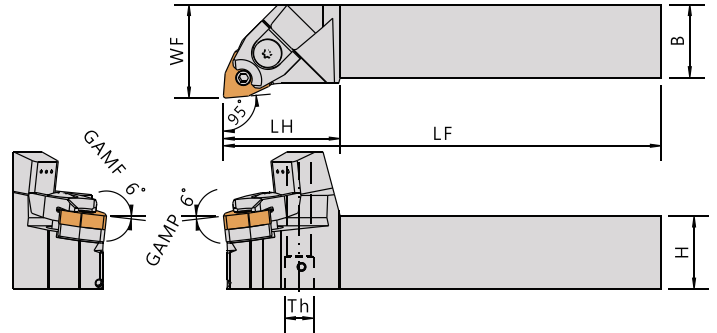
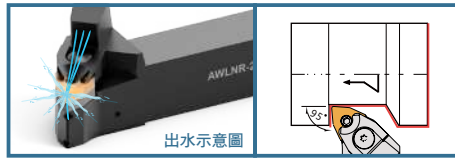

- Direct coolant supply through the turning tool.
- Shorten processing time by high cutting speed.
- 30 to 150% longer tool life for different kind of materials.
- Improved chip breaking, particularly at pressures above 40 bar.

Order No.	Insert	Dimensions(mm)						Parts							Wrench	
		柄高	柄寬	總長	頭長	寬度	牙孔	墊片	墊片螺絲	壓板	壓板彈簧	壓板螺絲	O型環	止付螺絲	板手	
Right / Left		H	B	LF	LH	WF	Th									
AWLNR-2525M08W		25	25	150	40	32	1/8"								TL-25	LW025 LW040
AWLNR-2525M08WP	WNMG0804	25	25	150	40	32	1/8"	SMW-433	LCS-520N	MTW-40	SP0816	CSB0623T	WS06	CS9NQ	TL-25	LW025 LW040
AWLNR-3232P08WP		32	32	170	40	40	1/8"								TL-25	LW025 LW040

WP : Multiple coolant direction 上下雙出水