

內孔車刀

Boring Bars



Since 1976



570-Shank diameter

刀柄

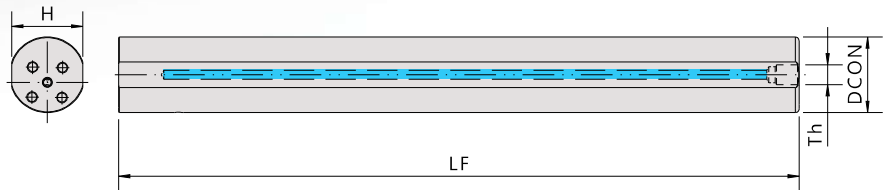

有水孔 With coolant

Order No.	Dimensions(mm)		
	柄徑 DCON	長度 LF	牙孔 TH
570-2C-16-105	16	105	1/8"
570-2C-20-140	20	140	1/8"
570-2C-25-200	25	200	1/4"
570-2C-32-220	32	220	1/4"
570-2C-40-280	40	280	1/4"
570-2C-50-360	50	360	1/4"
570-2C-50-400	50	400	1/4"
570-2C-60-460	60	460	1/4"

無水孔 Without coolant

Order No.	Dimensions(mm)		
	柄徑 DCON	長度 LF	牙孔 TH
570-2S-25-300	25	300	-
570-2S-32-350	32	350	-
570-2S-40-400	40	400	-
570-2S-50-450	50	450	-
570-2S-60-500	60	500	-
570-2S-63-460	63	460	-
570-2S-63-500	63	500	-

570-DCLN
95°

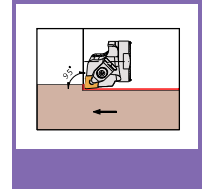
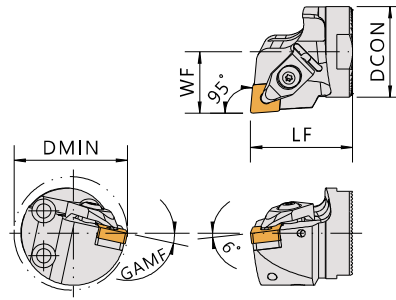

with coolant 有水孔

Order No.	Insert	Dimensions(mm)					Parts					Wrench	
		柄徑 DCON	工作寬度 WF	長度 LF	最小加工徑 DMIN	徑向前角 GAMF							
570-DCLNR-40-12	CNMG1204	40	27	38	50	12°	SMC-422	CSF4010	CP-D4	SP0816	CSB0620T	TL20	LW025

570-DTFN
91°

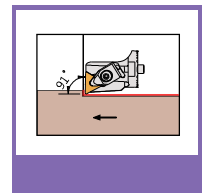
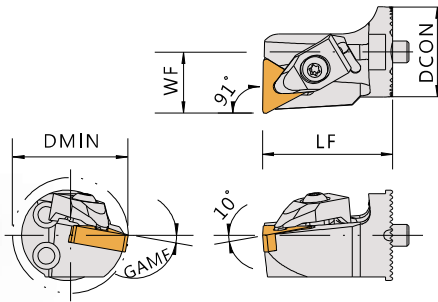

with coolant 有水孔

Order No.	Insert	Dimensions(mm)					Parts					Wrench	
		柄徑 DCON	工作寬度 WF	長度 LF	最小加工徑 DMIN	徑向前角 GAMF							
570-DTFNR-25-16	TNMG1604	25	17	36	32	10°	-	-	CP-D2	SP0612	CSB0415T	TL15	
570-DTFNR-32-16	TNMG1604	32	22	36	40	10°	SMT-323	CSA40075	CP-D2	SP0612	CSB0415T	TL15	

570-DTUN
93°

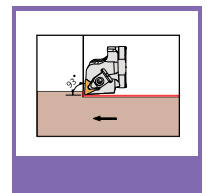
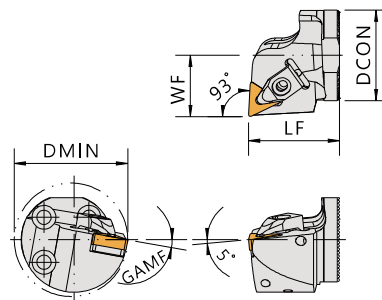

with coolant 有水孔

Order No.	Insert	Dimensions(mm)					Parts					Wrench	
		柄徑 DCON	工作寬度 WF	長度 LF	最小加工徑 DMIN	徑向前角 GAMF							
570-DTUNR-40-16	TNMG1604	40	27	38	50	10°	SMT-323	CSA40075	CP-D2	SP0612	CSB0415T	TL15	

570-DWLN

95°

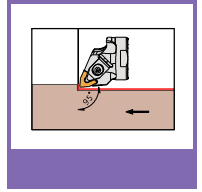
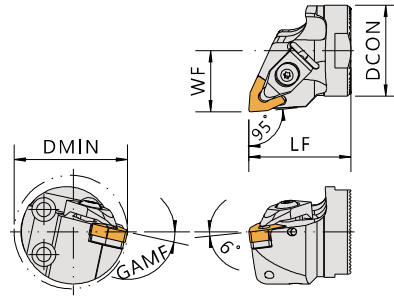

with coolant 有水孔

Order No.	Insert	Dimensions(mm)					Parts					Wrench
		柄徑	工作寬度	長度	最小加工徑	徑向前角						
Right / Left		DCON	WF	LF	DMIN	GAMF						
570-DWLN-40-08	WNMG0804	40	27	38	50	12°	SMW-423	CSF4010	CP-D4	SP0816	CSB0620T	TL20

570-MWLN

95°

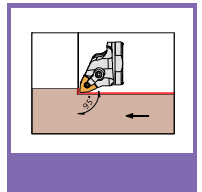
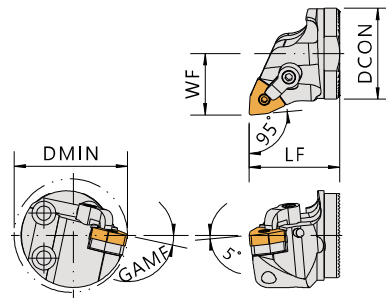

with coolant 有水孔

Order No.	Insert	Dimensions(mm)					Parts				Wrench	
		柄徑	工作寬度	長度	最小加工徑	徑向前角						
Right / Left		DCON	WF	LF	DMIN	GAMF						
570-MWLN-40-08	WNMG0804	40	27	38	50	12°	SMW-432	LCS-617	CP50-22	CS7-6030	-	LW030

570-PCLN

95°

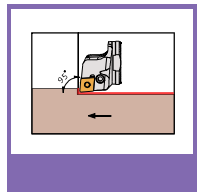
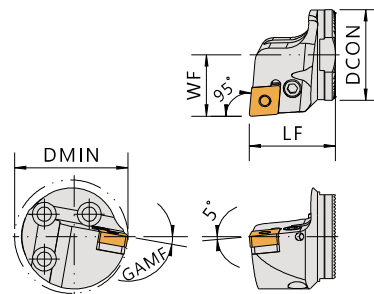

with coolant 有水孔

Order No.	Insert	Dimensions(mm)					Parts				Wrench
		柄徑	工作寬度	長度	最小加工徑	徑向前角					
Right / Left		DCON	WF	LF	DMIN	GAMF					
570-PCLN-40-12	CNMG1204	40	27	38	50	10°	SMC-422	CS-LSP4	CP-LL4	CS-LS4	LW030

570-PWLN

95°

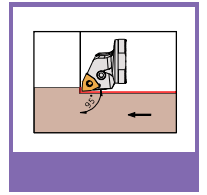
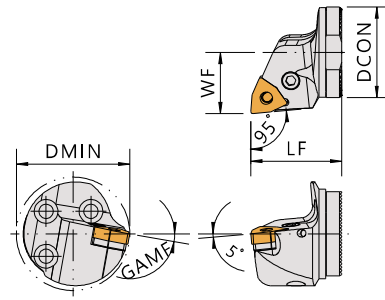

with coolant 有水孔

Order No.	Insert	Dimensions(mm)					Parts				Wrench
Right / Left		柄徑	工作寬度	長度	最小加工徑	徑向前角					
		DCON	WF	LF	DMIN	GAMF					
570-PWLNR-40-08	WNMG0804	40	27	38	50	8°	SMW-423	CS-LSP4	CP-LL4	CS-LS4	LW030

570-STFP

91°

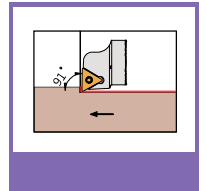
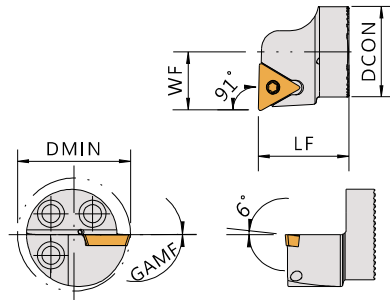

with coolant 有水孔

Order No.	Insert	Dimensions(mm)					Parts	Wrench
Right / Left		柄徑	工作寬度	長度	最小加工徑	徑向前角		
		DCON	WF	LF	DMIN	GAMF		
570-STFPR-16-11	TPMT1103	16	11	20	20	0°	CS25061S	FT-7
570-STFPR-20-11	TPMT1103	20	13	20	25	0°	CS25061S	FT-7

570-GNDIR

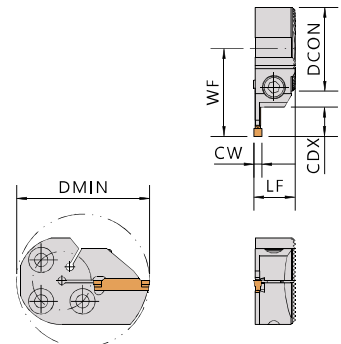
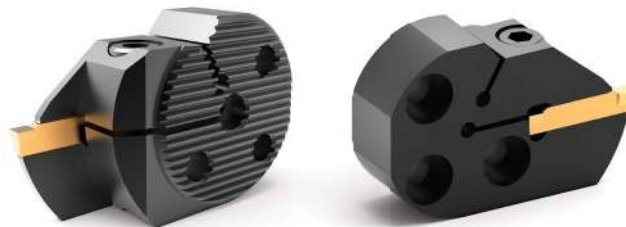

Order No.	Insert	Dimensions(mm)						Parts	Wrench
Right / Left		柄徑	工作寬度	長度	最小加工徑	切寬	最大切深		
		DCON	WF	LF	DMIN	CW	CDX		
570-GNDIR-32-T310	GCMN30	32	33	15.5	50	3	10	CSH0520	LW040

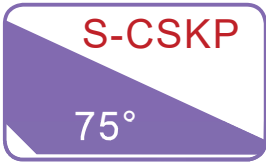

S-CSKP

75°

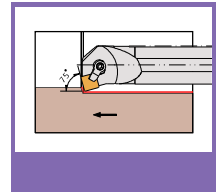
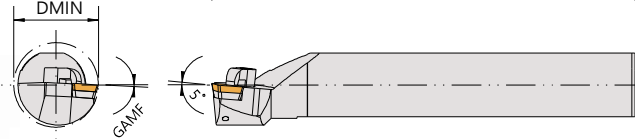

Order No.	Insert	Dimensions(mm)					Parts					Wrench
		柄徑 DCON	工作寬度 WF	長度 LF	最小加工徑 DMIN	徑向前角 GAMF						
S16Q-CSKPR/L09	SPMN0903	16	11	180	20	0°	-	-	CP50-21	CS7-5015	LW025	
S20R-CSKPR/L09		20	13	200	25	0°	-	-	CP50-21	CS7-5015	LW025	
S25R-CSKPR/L12	SPMN1203	25	17	200	32	2°	SMS-421	CSF3010	CP50-22	CS7-6024	LW030	
S32S-CSKPR/L12		32	22	250	40	0°	SMS-421	CSF3010	CP50-22	CS7-6024	LW030	

A- Steel shank with coolant
亦可做中心出水鋼柄

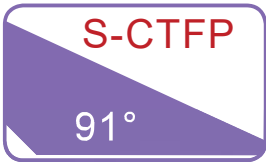

S-CTFP

91°

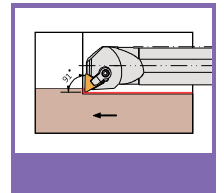
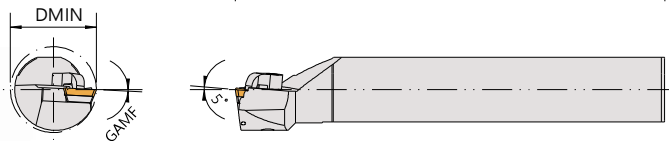

Order No.	Insert	Dimensions(mm)					Parts					Wrench
		柄徑 DCON	工作寬度 WF	長度 LF	最小加工徑 DMIN	徑向前角 GAMF						
S12M-CTFPR/L11	TPMN1103	12	9	150	16	6°	-	-	CP50-27S		LW025	
S16Q-CTFPR/L11		16	11	180	22	4°	-	-	CP50-21	CS7-5015	LW025	
S20R-CTFPR/L11		20	13	200	26	3°	-	-	CP50-21	CS7-5015	LW025	
S25R-CTFPR/L11		25	17	200	34	3°	-	-	CP50-21	CS7-5018	LW025	
S20R-CTFPR/L16	TPMN1603	20	13	200	26	0°	-	-	CP50-26	CS7-5015	LW025	
S25R-CTFPR/L16		25	17	200	34	3°	SMT-321	CS20045	CP50-22	CS7-6024	LW030	
S32S-CTFPR/L16		32	22	250	44	3°	SMT-321	CS20045	CP50-22	CS7-6024	LW030	

A- Steel shank with coolant
亦可做中心出水鋼柄

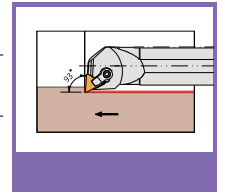
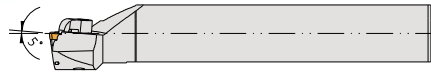
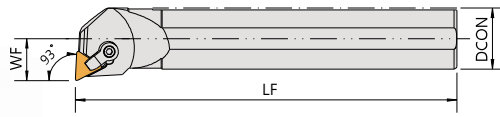
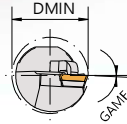
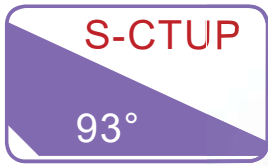

亦可做中心出水鋼柄
A- Steel shank with coolant

Order No.	Insert	Dimensions(mm)					Parts					Wrench
		柄徑 DCON	工作寬度 WF	長度 LF	最小加工徑 DMIN	徑向前角 GAMF						
S12M-CTUPR/L11	TPMN1103	12	9	150	16	6°	-	-	CP50-27AS		LW025	
S16Q-CTUPR/L11		16	11	180	20	3°	-	-	CP50-21	CS7-5015	LW025	
S20R-CTUPR/L11		20	13	200	25	3°	-	-	CP50-21	CS7-5015	LW025	
S25R-CTUPR/L16	TPMN1603	25	17	200	32	3°	SMT-321	CS20045	CP50-22	CS7-6024	LW030	
S32S-CTUPR/L16		32	22	250	40	3°	SMT-321	CS20045	CP50-22	CS7-6024	LW030	

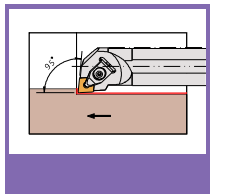
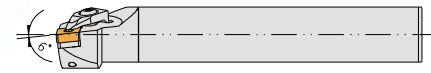
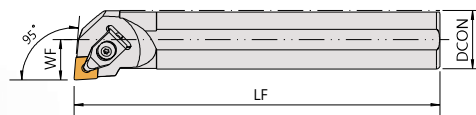
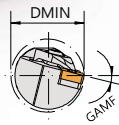
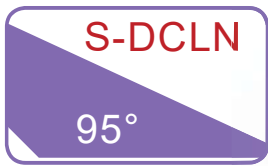

亦可做中心出水鋼柄
A- Steel shank with coolant

Order No.	Insert	Dimensions(mm)					Parts					Wrench	
		柄徑 DCON	工作寬度 WF	長度 LF	最小加工徑 DMIN	徑向前角 GAMF							
S25R-DCLNR/L12	CNMG1204	25	17	200	32	14°	SMC-422	CSF4010	CP-D4	SP0816	CSB0620T	TL20	LW025
S32S-DCLNR/L12		32	22	250	40	14°	SMC-422	CSF4010	CP-D4	SP0816	CSB0620T	TL20	LW025
S40T-DCLNR/L12		40	27	300	50	12°	SMC-422	CSF4010	CP-D4	SP0816	CSB0620T	TL20	LW025

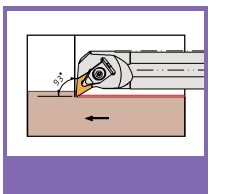
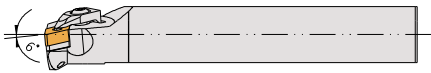
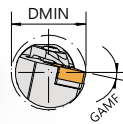
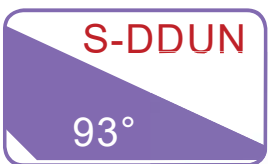

亦可做中心出水鋼柄
A- Steel shank with coolant

Order No.	Insert	Dimensions(mm)					Parts					Wrench	
		柄徑 DCON	工作寬度 WF	長度 LF	最小加工徑 DMIN	徑向前角 GAMF							
S25R-DDUNR/L15	DNMG1504-SMD443	25	17	200	32	16°	SMD-4XX	CSF4010	CP-D4	SP0816	CSB0620T	TL20	LW025
S32S-DDUNR/L15	DNMG1506-SMD424	32	22	250	40	12°	SMD-4XX	CSF4010	CP-D4	SP0816	CSB0620T	TL20	LW025
S40T-DDUNR/L15		40	27	300	50	10°	SMD-4XX	CSF4010	CP-D4	SP0816	CSB0620T	TL20	LW025

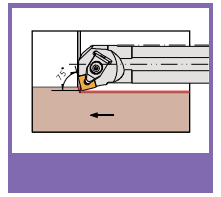
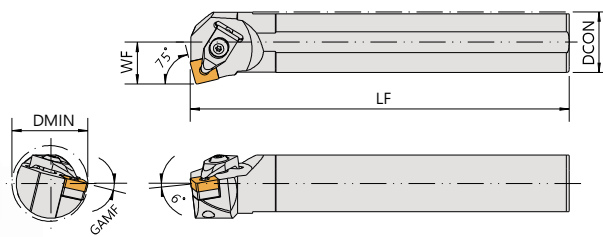

亦可做中心出水鋼柄
A- Steel shank with coolant

Order No.	Insert	Dimensions(mm)					Parts					Wrench
		柄徑	工作寬度	長度	最小加工徑	徑向前角						
Right / Left		DCON	WF	LF	DMIN	GAMF						
S25R-DSKNR/L12	SNMG1204	25	17	200	32	14°	-	-	CP-D4	SP0816	CSB0620T	TL20
S32S-DSKNR/L12		32	22	250	40	14°	SMS-422	CSF4010	CP-D4	SP0816	CSB0620T	TL20
S40V-DSKNR/L12		40	35	400	63	8°	SMS-432	CSF4010	CP-D4	SP0816	CSB0620T	TL20
S50V-DSKNR/L12		50	35	400	63	8°	SMS-432	CSF4010	CP-D4	SP0816	CSB0620T	TL20

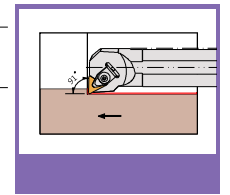
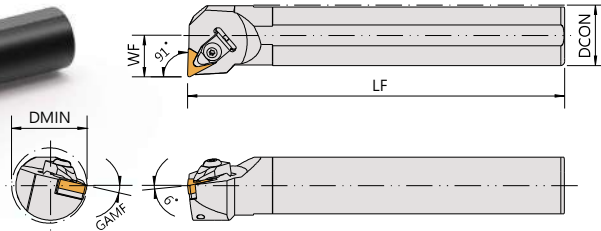
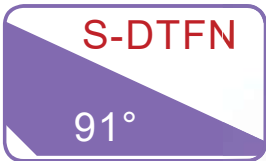

亦可做中心出水鋼柄
A- Steel shank with coolant

Order No.	Insert	Dimensions(mm)					Parts					Wrench
		柄徑	工作寬度	長度	最小加工徑	徑向前角						
Right / Left		DCON	WF	LF	DMIN	GAMF						
S25R-DTFNR/L16	TNMG1604	25	17	200	32	13°	SMT-323	CSA40075	CP-D2	SP0612	CSB0415T	TL15
S32S-DTFNR/L16		32	22	250	40	13°	SMT-323	CSA40075	CP-D2	SP0612	CSB0415T	TL15

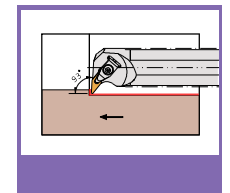
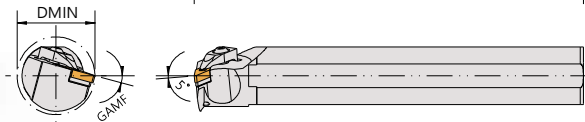
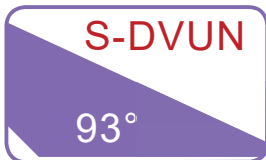

亦可做中心出水鋼柄
A- Steel shank with coolant

Order No.	Insert	Dimensions(mm)					Parts					Wrench
		柄徑	工作寬度	長度	最小加工徑	徑向前角						
Right / Left		DCON	WF	LF	DMIN	GAMF						
S40T-DVUNR/L16	VNMG1604	40	27	300	50	15°	SMV-322	CSA40075	CP-D3	SP0816	CSB0620T	TL20

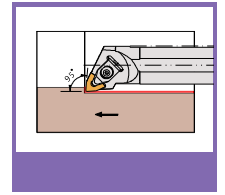
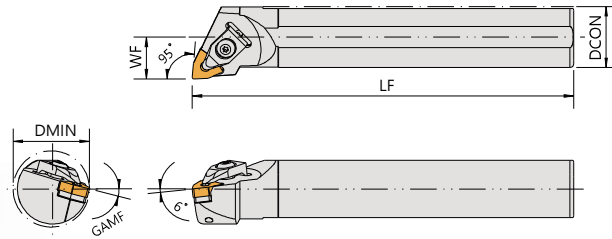
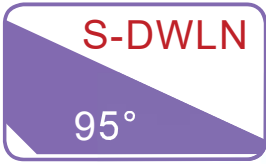

亦可做中心出水鋼柄
 A- Steel shank with coolant

Order No.	Insert	Dimensions(mm)					Parts						Wrench
		柄徑	工作寬度	長度	最小加工徑	徑向前角							
Right / Left		DCON	WF	LF	DMIN	GAMF							
S20R-DWLN/L06	WNMG0604	20	13	200	25	14°	-	-	CP-D2	SP0612	CSB0415T	TL15	
S25R-DWLN/L06		25	17	200	32	14°	SMW-322	CSA4009F	CP-D2	SP0612	CSB0415T	TL15	
S20R-DWLN/L08	WNMG0804	20	13	200	25	14°	-	-	CP-D4	SP0816	CSB0620T	TL20	
S25R-DWLN/L08		25	17	200	32	14°	SMW-423	CSF4010	CP-D4	SP0816	CSB0620T	TL20	
S32S-DWLN/L08		32	22	250	40	14°	SMW-423	CSF4010	CP-D4	SP0816	CSB0620T	TL20	
S40T-DWLN/L08		40	27	300	50	12°	SMW-423	CSF4010	CP-D4	SP0816	CSB0620T	TL20	

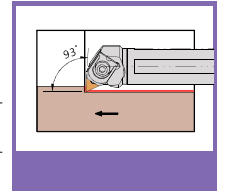
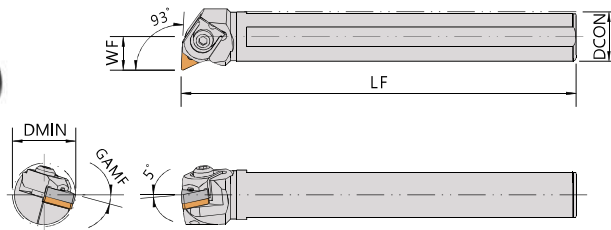
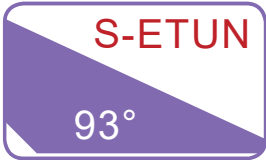

Order No.	Insert	Dimensions(mm)					Parts					Wrench
		柄徑	工作寬度	長度	最小加工徑	徑向前角						
Right / Left		DCON	WF	LF	DMIN	GAMF						
S20R-ETUNR16A	TNMG1604	10	16	200	16	15°						
S25R-ETUNR16A		12.5	17	200	16	15°	SMT-322	LCS-513	CPE-T16	CSE8026	ER31	LW025 LW050
S32S-ETUNR16A		16	22	250	20	10°						

A- Steel shank with coolant
 亦可做中心出水鋼柄

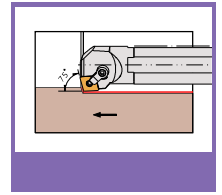
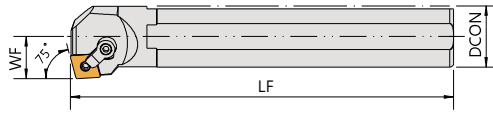
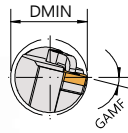
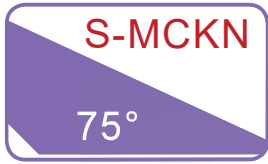

亦可做中心出水鋼柄
 A- Steel shank with coolant

Order No.	Insert	Dimensions(mm)					Parts				Wrench	
		柄徑	工作寬度	長度	最小加工徑	徑向前角						
Right / Left		DCON	WF	LF	DMIN	GAMF						
S20R-MCKNR/L12	CNMG1204	20	13	200	25	17°	-	LCS-511	CP50-26	CS7-5018	LW025	-
S25R-MCKNR/L12		25	17	200	32	14°	-	LCS-511	CP50-22	CS7-6024	LW025	LW030
S32S-MCKNR/L12		32	22	250	40	14°	SMC-432	LCS-617	CP50-22	CS7-6024	-	LW030
S40T-MCKNR/L12		40	27	300	50	12°	SMC-432	LCS-617	CP50-22	CS7-6030	-	LW030
S50U-MCKNR/L12		50	35	350	63	12°	SMC-432	LCS-617	CP50-22	CS7-6030	-	LW030

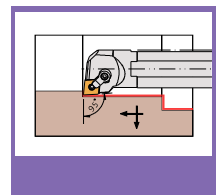
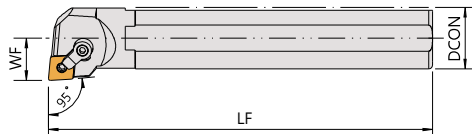
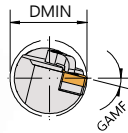
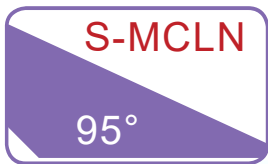

亦可做中心出水鋼柄
 A- Steel shank with coolant

Order No.	Insert	Dimensions(mm)					Parts				Wrench	
		柄徑	工作寬度	長度	最小加工徑	徑向前角						
Right / Left		DCON	WF	LF	DMIN	GAMF						
S16Q-MCLNR/L12	CNMG1204	16	11	180	20	20°	-	LCS-511	CP50-26	CS7-5018	LW025	-
S20R-MCLNR/L12		20	13	200	25	17°	-	LCS-511	CP50-26	CS7-5018	LW025	-
S20S-MCLNR/L12		20	13	250	25	17°	-	LCS-511	CP50-26	CS7-5018	LW025	-
S25R-MCLNR/L12		25	17	200	32	14°	-	LCS-511	CP50-22	CS7-6024	LW025	LW030
S32S-MCLNR/L12		32	22	250	40	14°	SMC-432	LCS-617	CP50-22	CS7-6030	-	LW030
S40T-MCLNR/L12		40	27	300	50	12°	SMC-432	LCS-617	CP50-22	CS7-6030	-	LW030
S50U-MCLNR/L12		50	35	350	63	12°	SMC-432	LCS-617	CP50-22	CS7-6030	-	LW030
S60V-MCLNR/L12		60	36	400	70	10°	SMC-432	LCS-617	CP50-22	CS7-6030	-	LW030
S63Y-MCLNR/L12		63	38	500	75	10°	SMC-432	LCS-617	CP50-22	CS7-6030	-	LW030
S40T-MCLNR/L16	CNMG1606	40	27	300	50	11°	SMC-533	LCS-0822	CP50-22	CS7-6030	-	LW030
S50U-MCLNR/L16		50	35	350	63	12°	SMC-533	LCS-0822	CP50-22	CS7-6030	-	LW030
S63Y-MCLNR/L16		63	38	500	75	10°	SMC-533	LCS-0822	CP50-22	CS7-6030	-	LW030
S50U-MCLNR/L19	CNMG1906	50	35	350	63	12°	SMC-633	LCS-0822	CP50-29	CS7-8030	-	LW030
S63Y-MCLNR/L19		63	38	500	75	10°	SMC-633	LCS-0822	CP50-29	CS7-8030	-	LW030

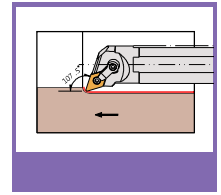
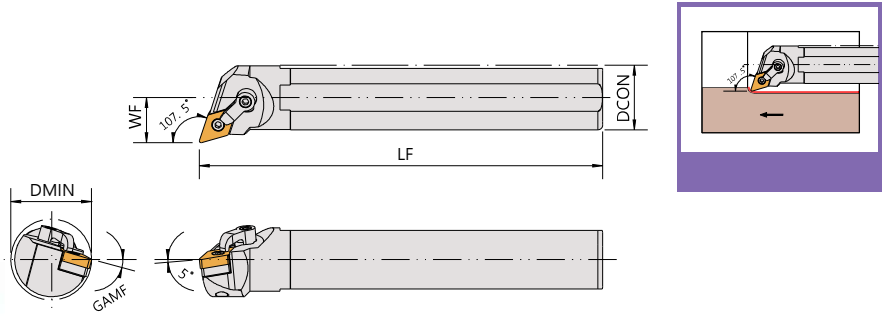
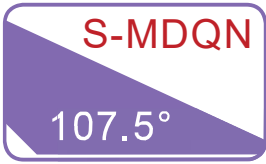

Order No.	Insert	Dimensions(mm)					Parts				Wrench
		柄徑 DCON	工作寬度 WF	長度 LF	最小加工徑 DMIN	徑向前角 GAMF					
S25R-MDQNR/L1504	DNMG1504	25	17	200	32	15°		LCS-617	CP50-24	CS7-6024	LW030
S32S-MDQNR/L15	DNMG1504-SMD463	32	22	250	40	17°	SMD-4X3	LCS-619	CP50-24	CS7-6024	LW030
S40T-MDQNR/L15	DNMG1506-SMD463	40	27	300	50	15°	SMD-4X3	LCS-619	CP50-24	CS7-6030	LW030
S50U-MDQNR/L15	DNMG1506-SMD443	50	35	350	63	12°	SMD-4X3	LCS-619	CP50-24	CS7-6030	LW030

A- Steel shank with coolant
亦可做中心出水鋼柄

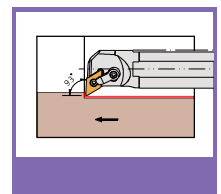
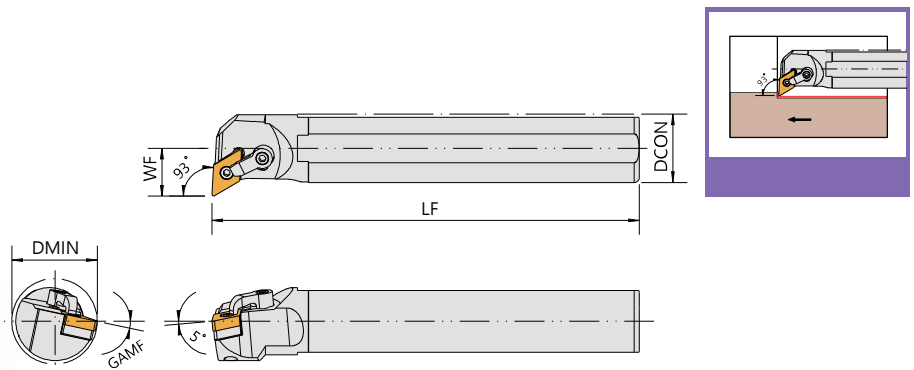
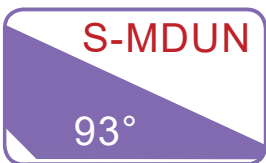

Order No.	Insert	Dimensions(mm)					Parts				Wrench
		柄徑 DCON	工作寬度 WF	長度 LF	最小加工徑 DMIN	徑向前角 GAMF					
S25R-MDUNR/L1504	DNMG1504	25	17	200	32	15°	-	LCS-511	CP50-24	CS7-6024	LW030
S32S-MDUNR/L15	DNMG1504-SMD463	32	22	250	40	17°	SMD-4X3	LCS-511	CP50-24	CS7-6024	LW030
S40T-MDUNR/L15	DNMG1506-SMD463	40	27	300	50	15°	SMD-4X3	LCS-511	CP50-24	CS7-6030	LW030
S50U-MDUNR/L15	DNMG1506-SMD443	50	35	350	63	12°	SMD-4X3	LCS-511	CP50-24	CS7-6030	LW030

A- Steel shank with coolant
亦可做中心出水鋼柄

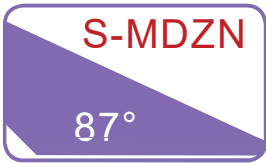

S-MDZN

87°

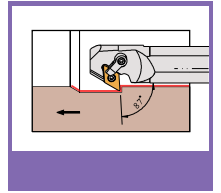
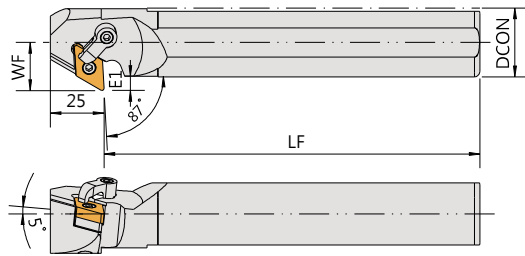
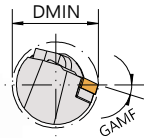

亦可做中心出水鋼柄
A- Steel shank with coolant

Order No.	Insert	Dimensions(mm)						Parts				Wrench
		柄徑 DCON	工作寬度 WF	切深 E1	長度 LF	最小加工徑 DMIN	徑向前角 GAMF					
S32S-MDZNR/L15	DNMG1504-SMD463	32	22	6	250	40	17°	SMD-4X3	LCS-619	CP50-24	CS7-6024	LW030
S40T-MDZNR/L15	DNMG1506-SMD443	40	27	7	300	50	15°	SMD-4X3	LCS-619	CP50-24	CS7-6030	LW030
S50U-MDZNR/L15	DNMG1506-SMD443	50	35	10	350	63	12°	SMD-4X3	LCS-619	CP50-24	CS7-6030	LW030

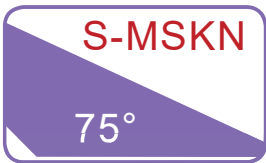

S-MSKN

75°

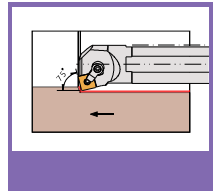
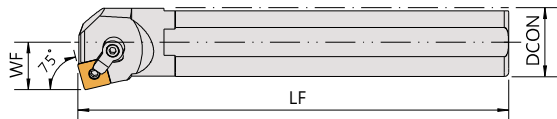
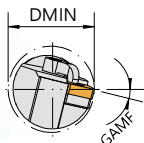

Order No.	Insert	Dimensions(mm)						Parts				Wrench
		柄徑 DCON	工作寬度 WF	長度 LF	最小加工徑 DMIN	徑向前角 GAMF						
S20R-MSKNR/L12	SNMG1204	20	13	200	25	17°	-	LCS-511	CP50-26	CS7-5018	LW025	-
S25R-MSKNR/L12		25	17	200	32	14°	-	LCS-511	CP50-22	CS7-6024	LW025	LW030
S32S-MSKNR/L12		32	22	250	40	14°	SMS-432	LCS-617	CP50-22	CS7-6030	-	LW030
S40T-MSKNR/L12		40	27	300	50	15°	SMS-432	LCS-617	CP50-22	CS7-6030	-	LW030
S50U-MSKNR/L12		50	35	350	63	12°	SMS-432	LCS-617	CP50-22	CS7-6030	-	LW030
S40T-MSKNR/L15	SNMG1506	40	27	300	50	15°	SMS-533	LCS-0822	CP50-22	CS7-6030	-	LW030
S50U-MSKNR/L19	SNMG1906	50	35	350	63	8°	SMS-633	LCS-1022	CP50-29	CS7-8030	-	LW030

亦可做中心出水鋼柄
A- Steel shank with coolant

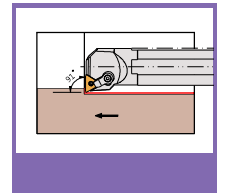
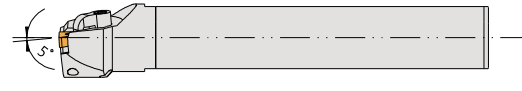
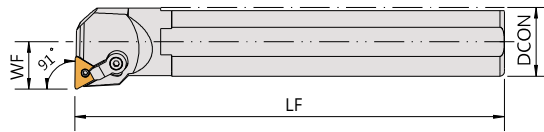
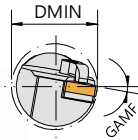
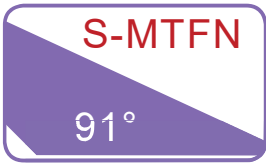

亦可做中心出水鋼柄
A- Steel shank with coolant

Order No.	Insert	Dimensions(mm)					Parts				Wrench	
		柄徑 DCON	工作寬度 WF	長度 LF	最小加工徑 DMIN	徑向前角 GAMF	△	螺絲	夾具	螺絲	L形扳手	
S20R-MTFNR/L16	TNMG1604	20	13	200	25	17°	-	LCS-510	CP50-26	CS7-5018	LW020	LW025
S20T-MTFNR/L16		20	13	300	25	17°	-	LCS-510	CP50-26	CS7-5018	LW020	LW025
S25R-MTFNR/L16		25	17	200	32	12°	-	LCS-510	CP50-22	CS7-6024	LW020	LW030
S32S-MTFNR/L16		32	22	250	40	10°	SMT-322	LCS-513	CP50-22	CS7-6024	LW020	LW030
S40T-MTFNR/L16		40	27	300	50	10°	SMT-322	LCS-513	CP50-22	CS7-6030	LW020	LW030
S50U-MTFNR/L16		50	35	350	63	8°	SMT-322	LCS-513	CP50-22	CS7-6030	LW020	LW030
S40T-MTFNR/L22	TNMG2204	40	27	300	50	15°	SMT-433	LCS-617	CP50-28	CS7-8030	LW030	LW040
S50U-MTFNR/L22		50	35	350	63	12°	SMT-433	LCS-617	CP50-28	CS7-8030	LW030	LW040

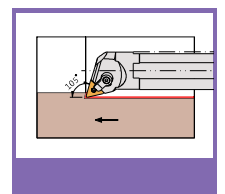
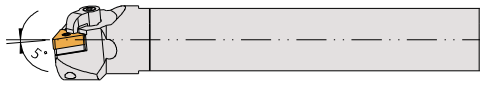
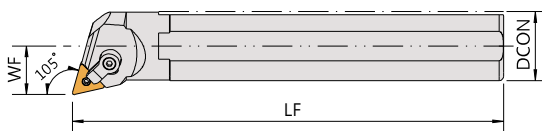
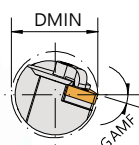
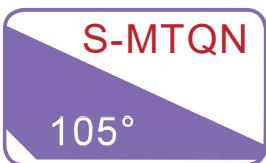

Order No.	Insert	Dimensions(mm)					Parts				Wrench	
		柄徑 DCON	工作寬度 WF	長度 LF	最小加工徑 DMIN	徑向前角 GAMF	△	螺絲	夾具	螺絲	L形扳手	
S20R-MTQNR/L16	TNMG1604	20	13	200	25	15°	-	LCS-510	CP50-26	CS7-5018	LW020	LW025
S25R-MTQNR/L16		25	17	200	32	12°	-	LCS-510	CP50-22	CS7-6024	LW020	LW030
S32S-MTQNR/L16		32	22	250	40	17°	SMT-322	LCS-513	CP50-22	CS7-6024	LW020	LW030
S40T-MTQNR/L16		40	27	300	50	15°	SMT-322	LCS-513	CP50-22	CS7-6030	LW020	LW030
S50U-MTQNR/L16		50	35	350	63	12°	SMT-322	LCS-513	CP50-22	CS7-6030	LW030	LW030

亦可做中心出水鋼柄
A- Steel shank with coolant

S-MTUN
S-MTUN-A
S-MTUN-AW
93°

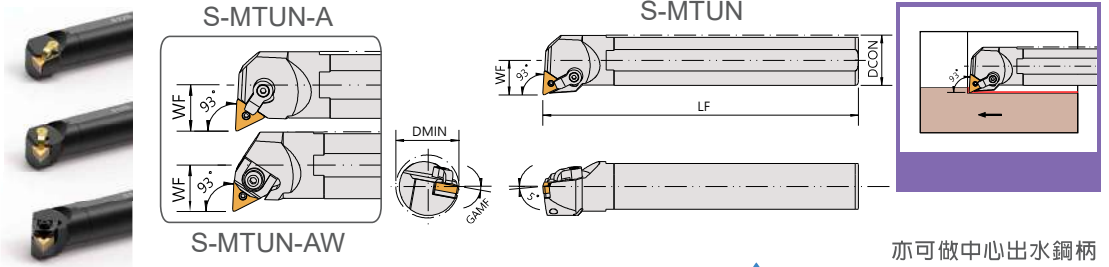

亦可做中心出水鋼柄
A- Steel shank with coolant

Order No.	Insert	Dimensions(mm)					Parts					Wrench		
		柄徑 DCON	工作寬度 WF	長度 LF	最小加工徑 DMIN	徑向前角 GAMF	△	🔩	🔧	🔩	🔩	🔩		
S16Q-MTUNR/L16	TNMG1604	16	11	180	20	20°	-	LCS-510	CP50-26S	CS7-5018	LW020	LW025		
S20R-MTUNR/L16		20	13	200	25	17°	-	LCS-510	CP50-26	CS7-5018	LW020	LW025		
S20S-MTUNR/L16		20	13	250	25	17°	-	LCS-510	CP50-26	CS7-5018	LW020	LW025		
S20T-MTUNR/L16		20	13	300	25	17°	-	LCS-510	CP50-26	CS7-5018	LW020	LW025		
S25R-MTUNR/L16		25	17	200	32	12°	-	LCS-510	CP50-22	CS7-6024	LW020	LW030		
S32S-MTUNR/L16		32	22	250	40	10°	SMT-322	LCS-513	CP50-22	CS7-6024	LW020	LW030		
S40T-MTUNR/L16		40	27	300	50	10°	SMT-322	LCS-513	CP50-22	CS7-6030	LW020	LW030		
S50U-MTUNR/L16		50	35	350	63	8°	SMT-322	LCS-513	CP50-22	CS7-6030	LW020	LW030		
S60V-MTUNR/L16		60	36	400	70	10°	SMT-322	LCS-513	CP50-22	CS7-6030	LW020	LW030		
S63Y-MTUNR/L16		63	38	500	75	10°	SMT-322	LCS-513	CP50-22	CS7-6030	LW020	LW030		
S40T-MTUNR/L22	TNMG2204	40	27	300	50	15°	SMT-433	LCS-617	CP50-28	CS7-8030	LW030	LW040		
S50U-MTUNR/L22		50	35	350	63	12°	SMT-433	LCS-617	CP50-28	CS7-8030	LW030	LW040		
S16Q-MTUNR/L16A	TNMG1604	16	11	180	20	20°	-	LCS-510	CP50-26S	CS7-5018	LW020	LW025		
S20R-MTUNR/L16A		20	13	200	25	17°	-	LCS-510	CP50-26	CS7-5018	LW020	LW025		
S20S-MTUNR/L16A		20	13	250	25	17°	-	LCS-510	CP50-26	CS7-5018	LW020	LW025		
S20T-MTUNR/L16A		20	13	300	25	17°	-	LCS-510	CP50-26	CS7-5018	LW020	LW025		
S25R-MTUNR/L16A		25	17	200	32	12°	-	LCS-510	CP50-22	CS7-6024	LW020	LW030		
S32S-MTUNR/L16A		32	22	250	40	10°	SMT-322	LCS-513	CP50-22	CS7-6024	LW020	LW030		
S40T-MTUNR/L16A		40	27	300	50	10°	SMT-322	LCS-513	CP50-22	CS7-6030	LW020	LW030		
S50U-MTUNR/L16A		50	35	350	63	8°	SMT-322	LCS-513	CP50-22	CS7-6030	LW020	LW030		
S60V-MTUNR/L16A		60	36	400	70	10°	SMT-322	LCS-513	CP50-22	CS7-6030	LW020	LW030		
S63Y-MTUNR/L16A		63	38	500	75	10°	SMT-322	LCS-513	CP50-22	CS7-6030	LW020	LW030		
S40T-MTUNR/L22A	TNMG2204	40	27	300	50	15°	SMT-433	LCS-617	CP50-28	CS7-8030	LW030	LW040		
S50U-MTUNR/L22A		50	35	350	63	12°	SMT-433	LCS-617	CP50-28	CS7-8030	LW030	LW040		
Right / Left	△	柄徑 DCON	工作寬度 WF	長度 LF	最小加工徑 DMIN	徑向前角 GAMF	△	🔩	🔧	🔩	🔩	🔩	🔩	
S20S-MTUNR16AW	TNMG1604	20	16	250	32	17°	SMT-322	LCS-420N	MTW-30	CSE5026	ER04	WS06	LW025	LW030
S25T-MTUNR16AW		25	17	300	32	12°	SMT-322	LCS-420N	MTW-30	CSE5026	ER04	WS06	LW025	LW030
S32U-MTUNR16AW		32	22	350	40	10°	SMT-322	LCS-420N	MTW-30	CSE5026	ER04	WS06	LW025	LW030
S40V-MTUNR16AW		40	27	400	50	10°	SMT-322	LCS-420N	MTW-30	CSE5026	ER04	WS06	LW025	LW030
S40V-MTUNR22AW	TNMG2204	40	27	400	50	10°	SMT-431	LCS-520W	MTW-34	CSE6027	ER05	WS06	LW025	LW030
S50W-MTUNR22AW		50	35	450	63	8°	SMT-431	LCS-520W	MTW-34	CSE6027	ER05	WS06	LW025	LW030

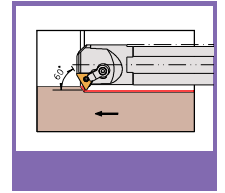
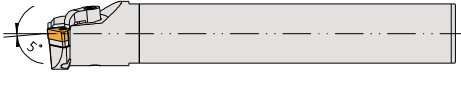
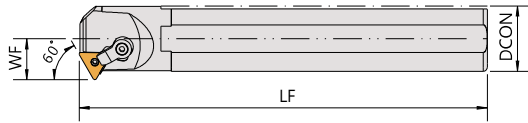
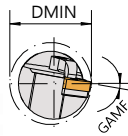
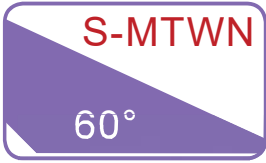

亦可做中心出水鋼柄
 A- Steel shank with coolant

Order No.	Insert	Dimensions(mm)					Parts					Wrench	
		柄徑 DCON	工作寬度 WF	長度 LF	最小加工徑 DMIN	徑向前角 GAMF							
S16Q-MTWN/L16	TNMG1604	16	11	180	20	20°	-	LCS-510	CP50-26S	CS7-5018	LW020	LW025	
S20R-MTWN/L16		20	13	200	25	17°	-	LCS-510	CP50-26	CS7-5018	LW020	LW025	
S25R-MTWN/L16		25	17	200	32	12°	-	LCS-510	CP50-22	CS7-6024	LW020	LW030	
S32S-MTWN/L16		32	20	250	40	10°	SMT-322	LCS-513	CP50-22	CS7-6024	LW020	LW030	
S40T-MTWN/L16		40	24	300	50	15°	SMT-322	LCS-513	CP50-22	CS7-6030	LW020	LW030	
S50U-MTWN/L16		50	29	350	57	12°	SMT-322	LCS-513	CP50-22	CS7-6030	LW020	LW030	

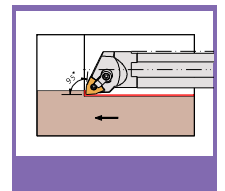
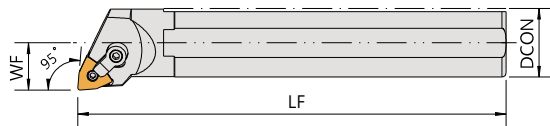
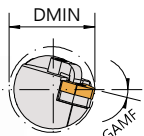
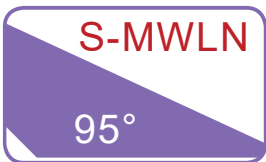

亦可做中心出水鋼柄
 A- Steel shank with coolant

Order No.	Insert	Dimensions(mm)					Parts					Wrench	
		柄徑 DCON	工作寬度 WF	長度 LF	最小加工徑 DMIN	徑向前角 GAMF							
S16Q-MWLN/L06	WNMG0604	16	11	180	22	18°	-	LCS-510	CP50-26	CS7-5018	LW020	LW025	
S20S-MWLN/L06		20	13	250	25	17°	-	LCS-510	CP50-26	CS7-5018	LW020	LW025	
S20R-MWLN/L08	WNMG0804	20	13	200	25	17°	-	LCS-511	CP50-26	CS7-5018	-	LW025	
S20S-MWLN/L08		20	13	250	25	17°	-	LCS-511	CP50-26	CS7-5018	-	LW025	
S20T-MWLN/L08		20	13	300	25	17°	-	LCS-511	CP50-26	CS7-5018	-	LW025	
S25R-MWLN/L08		25	17	200	32	14°	-	LCS-511	CP50-22	CS7-6024	LW025	LW030	
S32S-MWLN/L08		32	22	250	40	14°	SMW-432	LCS-617	CP50-22	CS7-6030	-	LW030	
S40T-MWLN/L08		40	27	300	50	12°	SMW-432	LCS-617	CP50-22	CS7-6030	-	LW030	
S50U-MWLN/L08		50	35	350	63	12°	SMW-432	LCS-617	CP50-22	CS7-6030	-	LW030	
S63Y-MWLN/L08		63	38	500	75	10°	SMW-432	LCS-617	CP50-22	CS7-6030	-	LW030	

S-MVPN
117.5°

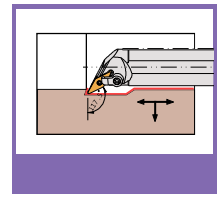
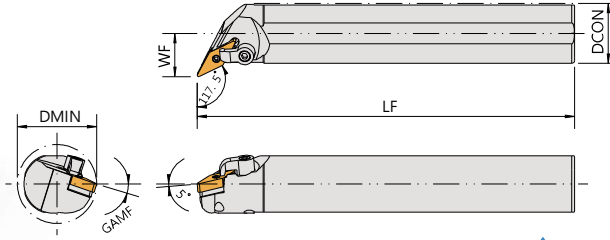

亦可做中心出水鋼柄
A- Steel shank with coolant

Order No.	Insert	Dimensions					Parts				Wrench	
		柄徑 DCON	工作寬度 WF	長度 LF	最小加工徑 DMIN	徑向前角 GAMF						
S25R-MVPNR/L16	VNMG1604	25	20	200	33	12°	SMV-322	LCS-513	CP50-22	CS7-6024	LW020	LW030
S32S-MVPNR/L16		32	23	250	40	17°	SMV-322	LCS-513	CP50-22	CS7-6024	LW020	LW030
S40T-MVPNR/L16		40	27	300	50	15°	SMV-322	LCS-513	CP50-22	CS7-6030	LW020	LW030
S50U-MVPNR/L16		50	33	350	63	12°	SMV-322	LCS-513	CP50-22	CS7-6030	LW020	LW030

S-MVQN
107.5°

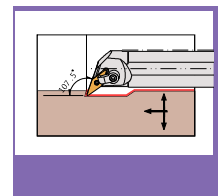
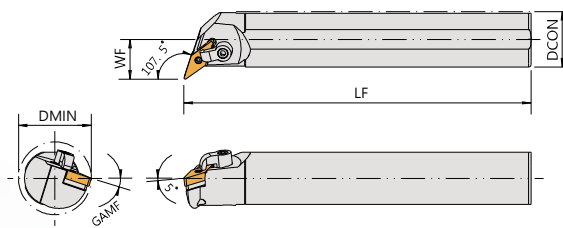

亦可做中心出水鋼柄
A- Steel shank with coolant

Order No.	Insert	Dimensions					Parts				Wrench	
		柄徑 DCON	工作寬度 WF	長度 LF	最小加工徑 DMIN	徑向前角 GAMF						
S25R-MVQNR/L16	VNMG1604	25	20	200	33	12°	SMV-322	LCS-513	CP50-22	CS7-6024	LW020	LW030
S32S-MVQNR/L16		32	23	250	40	17°	SMV-322	LCS-513	CP50-22	CS7-6024	LW020	LW030
S40T-MVQNR/L16		40	27	300	50	15°	SMV-322	LCS-513	CP50-22	CS7-6030	LW020	LW030
S50U-MVQNR/L16		50	33	350	63	12°	SMV-322	LCS-513	CP50-22	CS7-6030	LW020	LW030

S-MVUN
93°

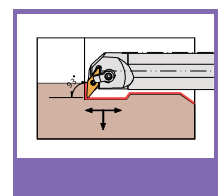
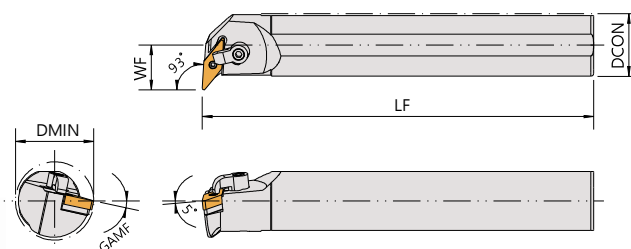

亦可做中心出水鋼柄
A- Steel shank with coolant

Order No.	Insert	Dimensions					Parts				Wrench	
		柄徑 DCON	工作寬度 WF	長度 LF	最小加工徑 DMIN	徑向前角 GAMF						
S25R-MVUNR/L16	VNMG1604	25	20	200	37	12°	SMV-322	LCS-513	CP50-22	CS7-6024	LW020	LW030
S32S-MVUNR/L16		32	22	250	40	12°	SMV-322	LCS-513	CP50-22	CS7-6030	LW020	LW030
S40T-MVUNR/L16		40	27	300	50	15°	SMV-322	LCS-513	CP50-22	CS7-6030	LW020	LW030
S50U-MVUNR/L16		50	32	350	63	12°	SMV-322	LCS-513	CP50-22	CS7-6030	LW020	LW030

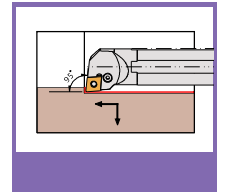
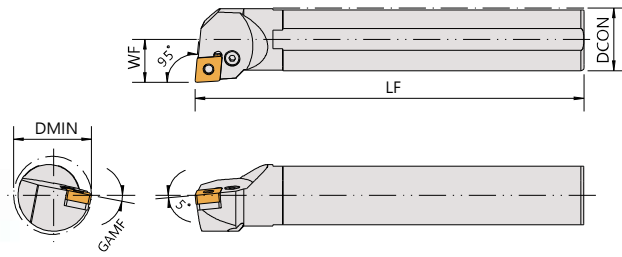
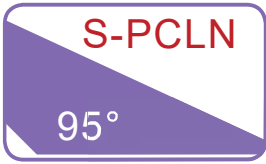

Order No.	Insert	Dimensions					Parts				Wrench
		柄徑	工作寬度	長度	最小加工徑	徑向前角					
Right / Left		DCON	WF	LF	DMIN	GAMF					
S16Q-PCLNR/L09	CNMG0903	16	11	180	20	14°	-	CS-LSP2	CP-LL2	CS-LS2	LW025
S20R-PCLNR/L09		20	13	200	25	12°	-	CS-LSP2	CP-LL2	CS-LS2	LW025
S25R-PCLNR/L09		25	17	200	32	11°	SMC-322	CS-LSP3	CP-LL3	CS-LS3	LW025
S25R-PCLNR/L12	CNMG1204	25	17	200	32	11°	-	CS-LSP5	CP-LL5	CS-LS3	LW025
S32S-PCLNR/L12		32	22	250	40	11°	SMC-422	CS-LSP4	CP-LL4	CS-LS4	LW030
S40T-PCLNR/L12		40	27	300	50	10°	SMC-422	CS-LSP4	CP-LL4	CS-LS4	LW030
S50W-PCLNR/L19	CNMG1906	50	35	450	63	10°	SMC-632	CS-LSP8	CP-LL8	CS-LS8	LW040

💧 A- Steel shank with coolant
亦可做中心出水鋼柄

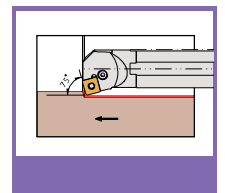
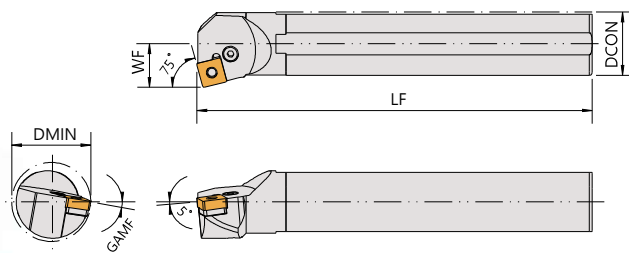

Order No.	Insert	Dimensions					Parts				Wrench
		柄徑	工作寬度	長度	最小加工徑	徑向前角					
Right / Left		DCON	WF	LF	DMIN	GAMF					
S25R-PSKNR/L12	SNMG1204	25	17	200	30	10°	-	CS-LSP5	CP-LL5	CS-LS3	LW025
S32S-PSKNR/L12		32	22	250	40	10°	SMS-422	CS-LSP4	CP-LL4	CS-LS4	LW030
S40T-PSKNR/L12		40	27	300	48	10°	SMS-422	CS-LSP4	CP-LL4	CS-LS4	LW030

💧 A- Steel shank with coolant
亦可做中心出水鋼柄

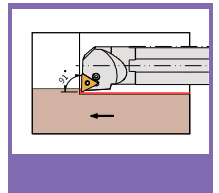
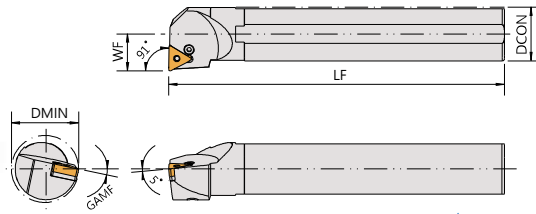
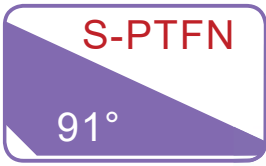

亦可做中心出水鋼柄
A- Steel shank with coolant

Order No.	Insert	Dimensions					Parts				Wrench
		柄徑 DCON	工作寬度 WF	長度 LF	最小加工徑 DMIN	徑向前角 GAMF					
S20R-PTFNR/L16	TNMG1604	20	13	200	25	18°	SMT-31T	CS-LSP3	CP-LL6	CS-LS6	LW030
S25R-PTFNR/L16		25	17	200	30	15°	SMT-31T	CS-LSP3	CP-LL3	CS-LS3	LW025
S32S-PTFNR/L16		32	22	250	40	12°	SMT-31T	CS-LSP3	CP-LL3	CS-LS3	LW025
S40T-PTFNR/L16		40	27	300	48	10°	SMT-31T	CS-LSP3	CP-LL3	CS-LS3	LW025

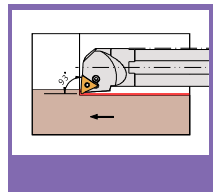
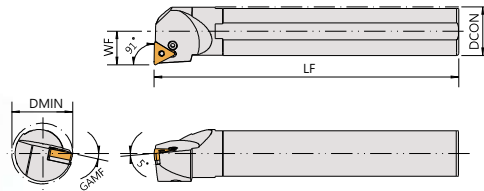
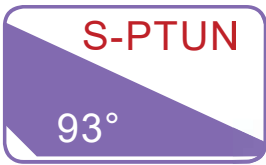

亦可做中心出水鋼柄
A- Steel shank with coolant

Order No.	Insert	Dimensions					Parts				Wrench
		柄徑 DCON	工作寬度 WF	長度 LF	最小加工徑 DMIN	徑向前角 GAMF					
S20R-PTUNR/L16	TNMG1604	20	13	200	25	18°	SMT-31T	CS-LSP3	CP-LL6	CS-LS6	LW030
S25R-PTUNR/L16		25	17	200	30	15°	SMT-31T	CS-LSP3	CP-LL3	CS-LS3	LW025
S32S-PTUNR/L16		32	22	250	40	12°	SMT-31T	CS-LSP3	CP-LL3	CS-LS3	LW025
S40T-PTUNR/L16		40	27	300	48	10°	SMT-31T	CS-LSP3	CP-LL3	CS-LS3	LW025

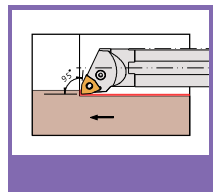
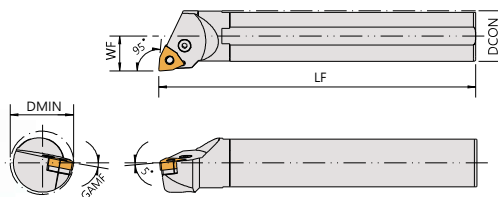
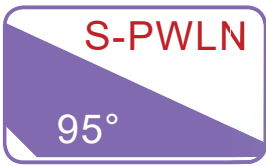

亦可做中心出水鋼柄
A- Steel shank with coolant

Order No.	Insert	Dimensions					Parts				Wrench
		柄徑 DCON	工作寬度 WF	長度 LF	最小加工徑 DMIN	徑向前角 GAMF					
S16R-PWLN/L06	WNMG0604	16	11	200	20	14°	-	CS-LSP2	CP-LL2	CS-LS2	LW025
S20S-PWLN/L06		20	13	250	25	12°	-	CS-LSP2	CP-LL2	CS-LS2	LW025
S25T-PWLN/L06		25	17	300	32	12°	-	CS-LSP2	CP-LL2	CS-LS2	LW025
S32U-PWLN/L06		32	22	350	40	10°	SMW-322	CS-LSP3	CP-LL3	CS-LS3	LW025
S25R-PWLN/L08	WNMG0804	25	17	200	30	12°	-	CS-LSP5	CP-LL5	CS-LS3	LW025
S32S-PWLN/L08		32	22	250	40	10°	SMW-423	CS-LSP4	CP-LL4	CS-LS4	LW030
S40T-PWLN/L08		40	27	300	48	8°	SMW-423	CS-LSP4	CP-LL4	CS-LS4	LW030

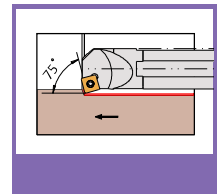
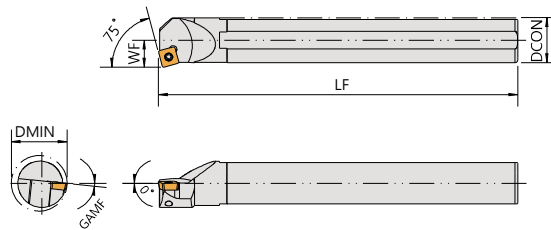
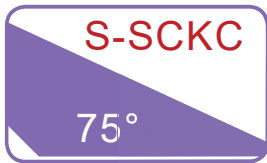

亦可做中心出水鋼柄
 A- Steel shank with coolant

Order No.	Insert	Dimensions(mm)					Parts	Wrench
		柄徑	工作寬度	長度	最小加工徑	徑向前角		
Right / Left		DCON	WF	LF	DMIN	GAMF		
S08H-SCKCR/L06	CCMT0602	8	6	100	12	13°	CS25050	FT-7
S10K-SCKCR/L06		10	7	125	14	12°	CS25061S	FT-7
S12M-SCKCR/L06		12	9	150	16	9°	CS25061S	FT-7
S16Q-SCKCR/L06		16	9.5	180	20	7°	CS25061S	FT-7
S12M-SCKCR/L09	CCMT09T3	12	8	150	16	13°	CS35075	FT-15
S16Q-SCKCR/L09		16	11	180	20	9°	CS35090	FT-15
S20R-SCKCR/L09		20	13	200	25	7°	CS35090	FT-15
S25R-SCKCR/L09		25	17	200	32	5°	CS35090	FT-15

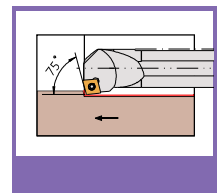
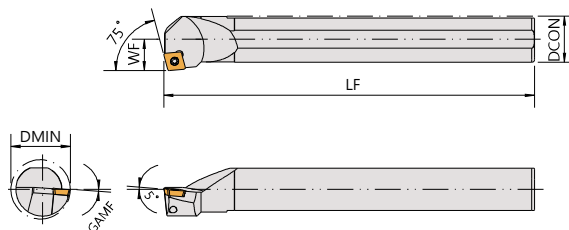
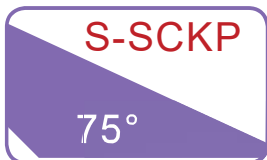

亦可做中心出水鋼柄
 A- Steel shank with coolant

Order No.	Insert	Dimensions(mm)					Parts	Wrench
		柄徑	工作寬度	長度	最小加工徑	徑向前角		
Right / Left		DCON	WF	LF	DMIN	GAMF		
S08H-SCKPR/L06	CPMT0602	8	6	100	10	10°	CS25050	FT-7
S10K-SCKPR/L06		10	7	125	13	8°	CS25061S	FT-7
S12M-SCKPR/L06		12	9	150	16	6°	CS25061S	FT-7
S16Q-SCKPR/L06		16	11	180	20	6°	CS25061S	FT-7
S12M-SCKPR/L09	CPMT0903	12	9	150	16	6°	CS40090	FT-15
S16Q-SCKPR/L09		16	11	180	20	4°	CS40090	FT-15
S20R-SCKPR/L09		20	13	200	25	4°	CS40090	FT-15
S25R-SCKPR/L09		25	17	200	32	4°	CS40090	FT-15

S-SCLC
S-SCLC-S
95°

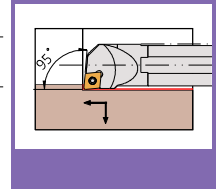
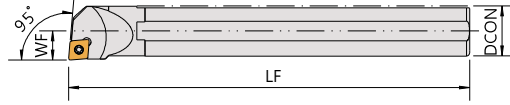
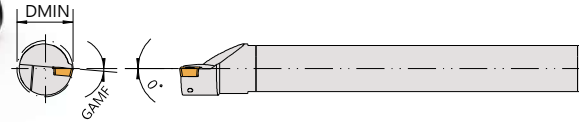

亦可做中心出水鋼柄
A- Steel shank with coolant

Order No.	Insert	Dimensions(mm)					Parts			Wrench	
		柄徑 DCON	工作寬度 WF	長度 LF	最小加工徑 DMIN	徑向前角 GAMF					
S08H-SCLCR/L06	CCMT0602	8	6	100	12	13°	-	-	CS25050	FT-7	-
S08H-SCLCR/L06-10		8	5	100	10	13°	-	-	CS25050	FT-7	-
S10K-SCLCR/L06		10	7	125	14	12°	-	-	CS25061S	FT-7	-
S10K-SCLCR/L06-12		10	6	125	12	12°	-	-	CS25061S	FT-7	-
S12M-SCLCR/L06		12	9	150	16	9°	-	-	CS25061S	FT-7	-
S12M-SCLCR/L06-14		12	7	150	14	9°	-	-	CS25061S	FT-7	-
S16Q-SCLCR/L06		16	11	180	20	7°	-	-	CS25061S	FT-7	-
S16Q-SCLCR/L06-18		16	9	180	18	7°	-	-	CS25061S	FT-7	-
S08H-SCLCR08	CCMT0804	8	6	100	12	12°	-	-	CS30070	FT-10	-
S10K-SCLCR08		10	7	125	14	12°	-	-	CS30070	FT-10	-
S10K-SCLCR08-12		10	6	125	12	12°	-	-	CS30070	FT-10	-
S12M-SCLCR08-14		12	7	150	14	12°	-	-	CS30070	FT-10	-
S16Q-SCLCR08-18		16	9	180	18	9°	-	-	CS30070	FT-10	-
S20R-SCLCR08-22		20	11	200	22	7°	-	-	CS30070	FT-10	-
S12M-SCLCR/L09	CCMT09T3	12	9	150	16	13°	-	-	CS35075	FT-15	-
S12M-SCLCR/L09-14		12	7	150	14	13°	-	-	CS35075	FT-15	-
S16Q-SCLCR/L09		16	11	180	20	9°	-	-	CS35075	FT-15	-
S16Q-SCLCR/L09-18		16	9	180	18	9°	-	-	CS35075	FT-15	-
S20R-SCLCR/L09		20	13	200	25	7°	-	-	CS35090	FT-15	-
S20S-SCLCR/L09		20	13	250	25	7°	-	-	CS35090	FT-15	-
S20R-SCLCR/L09-22		20	11	200	22	5°	-	-	CS35090	FT-15	-
S25R-SCLCR/L09		25	17	200	32	5°	-	-	CS35090	FT-15	-
S25R-SCLCR/L09-28		25	14.5	200	28	5°	-	-	CS35090	FT-15	-
S32S-SCLCR/L09		32	22	250	40	5°	-	-	CS35090	FT-15	-
S20R-SCLCR/L12	CCMT1204	20	13	200	25	8°	-	-	CS40115	FT-15	-
S25R-SCLCR/L12		25	17	200	32	8°	-	-	CS40115	FT-15	-
S32S-SCLCR/L12S	CCMT1204	32	22	250	40	6°	SMC-453	SN630	CS40145	FT-15	LW040
S40T-SCLCR/L12S		40	27	300	50	4°					

C-SCLC
E-SCLC
L-SCLC
95°

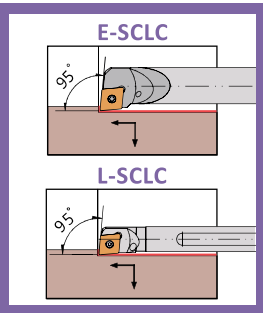
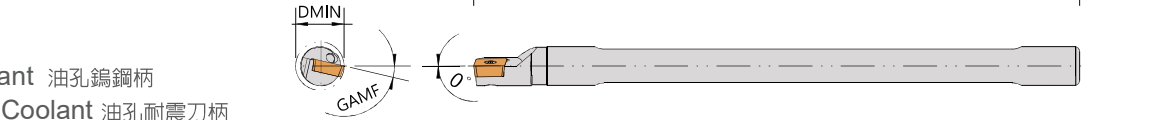
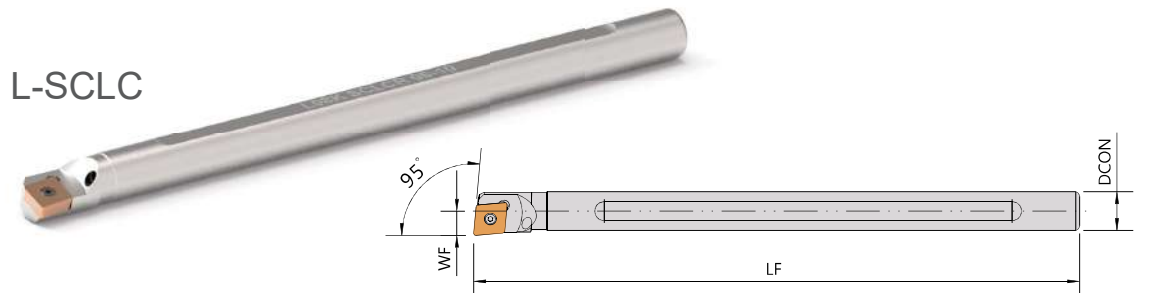
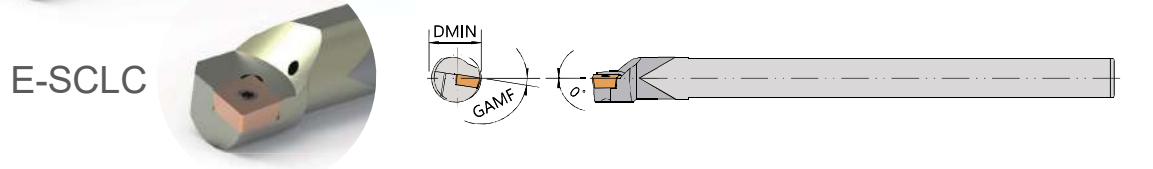
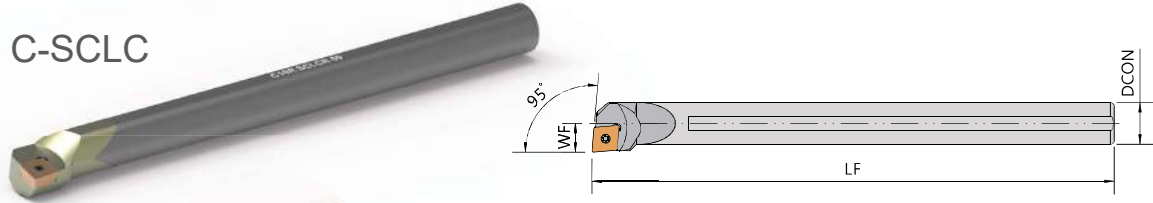

C-Carbide Shank 鎢鋼柄
E-Carbide Shank with Coolant 油孔鎢鋼柄
L-Anti-vibration Shank with Coolant 油孔耐震刀柄

Order No.	Insert	Dimensions(mm)					Parts	Wrench
		柄徑 DCON	工作寬度 WF	長度 LF	最小加工徑 DMIN	徑向前角 GAMF		
C08K-SCLCR06-10	CCMT0602	8	5	125	10	13°	CS25050	FT-7
C10M-SCLCR06-12		10	6	150	12	7°	CS25061S	FT-7
C12Q-SCLCR06-14		12	7	180	14	6°	CS25061S	FT-7
C16R-SCLCR06-18		16	9	200	18	7°	CS25061S	FT-7
C12Q-SCLCR09-14	CCMT09T3	12	7	180	14	6°	CS35075	FT-15
C16R-SCLCR09-18		16	9	200	18	7°	CS35075	FT-15
C20S-SCLCR09-22		20	11	250	22	5°	CS35090	FT-15
C25T-SCLCR09-28		25	14.5	300	28	5°	CS35090	FT-15
E08M-SCLCR06-10	CCMT0602	8	5	150	10	9°	CS25050	FT-7
E10Q-SCLCR06-12		10	6	180	12	7°	CS25061S	FT-7
E12R-SCLCR06-14		12	7	200	14	6°	CS25061S	FT-7
E12R-SCLCR09-14	CCMT09T3	12	7	200	14	6°	CS35075	FT-15
E16R-SCLCR09-18		16	9	200	18	7°	CS35075	FT-15
E20S-SCLCR09-22		20	11	250	22	5°	CS35090	FT-15
E25T-SCLCR09-28		25	14.5	300	28	5°	CS35090	FT-15
L08K-SCLCR06-10	CCMT0602	8	5	125	10	9°	CS25050	FT-7
L10K-SCLCR06-12		10	6	125	12	7°	CS25061S	FT-7
L12M-SCLCR06-14		12	7	150	14	6°	CS25061S	FT-7
L16R-SCLCR09-18	CCMT09T3	16	9	200	18	6°	CS35075	FT-15

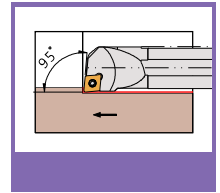
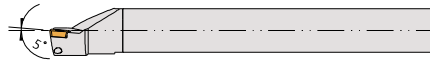
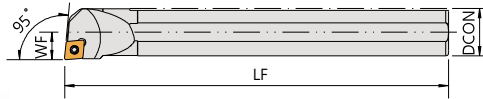
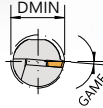
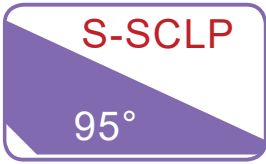

亦可做中心出水鋼柄
A- Steel shank with coolant

Order No.	Insert	Dimensions(mm)					Parts	Wrench
		柄徑	工作寬度	長度	最小加工徑	徑向前角		
Right / Left		DCON	WF	LF	DMIN	GAMF		
S08H-SCLPR/L06	CPMT0602	8	6	100	12	7°	CS25050	FT-7
S10K-SCLPR/L06		10	7	125	14	7°	CS25061S	FT-7
S12M-SCLPR/L06		12	9	150	16	6°	CS25061S	FT-7
S10K-SCLPR/L08	CPMT0802	10	7	125	14	7°	CS30070	FT-10
S10K-SCLPR/L08-12		10	6	125	12	7°	CS30070	FT-10
S12M-SCLPR/L08		12	8	150	16	6°	CS30070	FT-10
S12M-SCLPR/L08-14		12	7	150	14	6°	CS30070	FT-10
S16Q-SCLPR/L08	CPMT0903	16	9	180	18	7°	CS30070	FT-10
S12M-SCLPR/L09		12	9	150	16	12°	CS40090	FT-15
S16Q-SCLPR/L09		16	11	180	20	7°	CS40090	FT-15
S16Q-SCLPR/L09-18		16	9	180	18	7°	CS40090	FT-15
S20R-SCLPR/L09		20	13	200	25	5°	CS40090	FT-15
S20S-SCLPR/L09		20	13	250	25	5°	CS40090	FT-15
S20R-SCLPR/L09-22		20	11	200	22	5°	CS40090	FT-15
S25R-SCLPR/L09		25	17	200	32	5°	CS40090	FT-15
S25R-SCLPR/L09-28		25	14.5	200	28	5°	CS40090	FT-15
S32S-SCLPR/L09	32	17.5	250	39	5°	CS40090	FT-15	

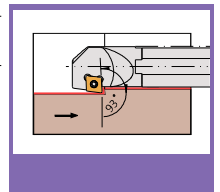
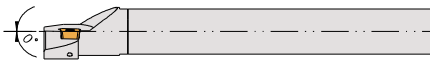
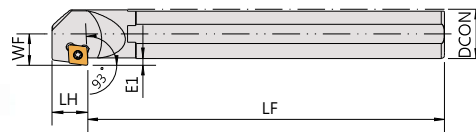
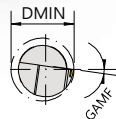
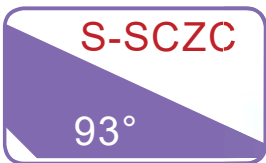

亦可做中心出水鋼柄
A- Steel shank with coolant

Order No.	Insert	Dimensions(mm)							Parts	Wrench
		柄徑	工作寬度	切深	長度	最小加工徑	頭長	徑向前角		
Right / Left		DCON	WF	E1	LF	DMIN	LH	GAMF		
S08H-SCZCR/L06	CCMT0602	8	6.5	2.5	100	12	10	13°	CS25050	FT-7
S10K-SCZCR/L06		10	7.5	2.5	125	14	10	12°	CS25061S	FT-7
S12M-SCZCR/L06		12	8.5	2.5	150	16	10	10°	CS25061S	FT-7
S16Q-SCZCR/L09	CCMT09T3	16	11.5	3.5	180	21	16	10°	CS35090	FT-15
S20R-SCZCR/L09		20	13.5	3.5	200	25	18	8°	CS35090	FT-15
S25R-SCZCR/L09		25	16	3.5	200	32	18	8°	CS35090	FT-15

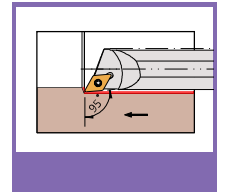
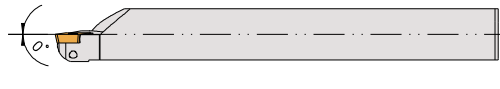
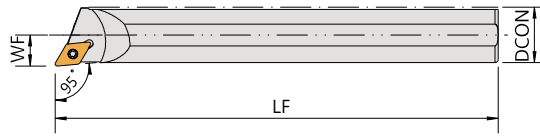
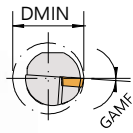
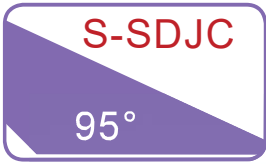

亦可做中心出水鋼柄
 A- Steel shank with coolant

Order No.	Insert	Dimensions(mm)					Parts	Wrench
		柄徑	工作寬度	長度	最小加工徑	徑向前角		
Right / Left		DCON	WF	LF	DMIN	GAMF		
S08K-SDJCR/L07	DCMT0702	8	5	125	11	10°	CS25050	FT-7
S10M-SDJCR/L07		10	6	150	13	10°	CS25061S	FT-7
S12M-SDJCR/L07		12	7	150	19	10°	CS25061S	FT-7
S16Q-SDJCR/L07		16	9.5	180	23	8°	CS25061S	FT-7
S16Q-SDJCR/L11	DCMT11T3	16	9.5	180	23	8°	CS35095	FT-15
S20R-SDJCR/L11		20	11.5	200	27	6°	CS35095	FT-15
S25R-SDJCR/L11		25	14	200	32	4°	CS35095	FT-15
S32S-SDJCR/L11		32	17.5	250	40	2°	CS35095	FT-15

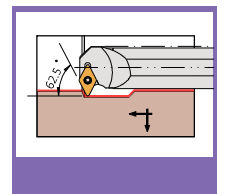
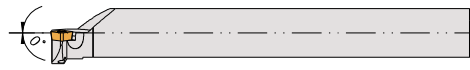
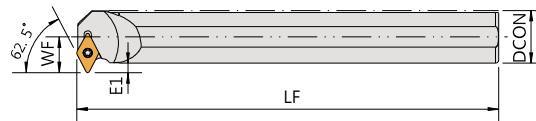
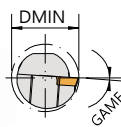
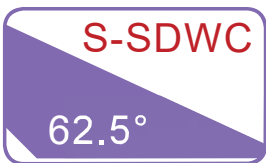

亦可做中心出水鋼柄
 A- Steel shank with coolant

Order No.	Insert	Dimensions(mm)						Parts	Wrench
		柄徑	工作寬度	切深	長度	最小加工徑	徑向前角		
Right / Left		DCON	WF	E1	LF	DMIN	GAMF		
S10K-SDWCR/L07	DCMT0702	10	9.5	4.5	125	17	12°	CS25061S	FT-7
S12M-SDWCR/L07		12	10.5	4.5	150	19	10°	CS25061S	FT-7
S16Q-SDWCR/L07		16	12.5	4.5	180	23	8°	CS25061S	FT-7
S20R-SDWCR/L07		20	14.5	4.5	200	27	6°	CS25061S	FT-7
S16Q-SDWCR/L11	DCMT11T3	16	12.5	4.5	180	23	8°	CS35095	FT-15
S20R-SDWCR/L11		20	14.5	4.5	200	27	6°	CS35095	FT-15
S20T-SDWCR/L11		20	14.5	4.5	300	27	6°	CS35095	FT-15
S25R-SDWCR/L11		25	17	4.5	200	32	4°	CS35095	FT-15
S32S-SDWCR/L11		32	20	4	250	40	2°	CS35095	FT-15

S-SDQC
C-SDQC
E-SDQC

107.5°

S-Steel Shank 鋼柄
C-Carbide Shank 鑄鋼柄
E-Carbide Shank with Coolant 油孔鑄鋼柄

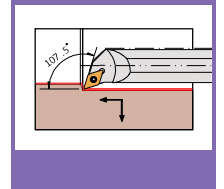
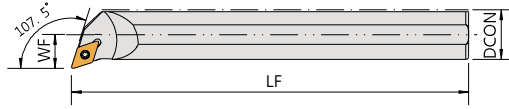
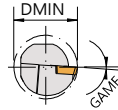

Order No.	Insert	Dimensions(mm)					Parts	Wrench
		柄徑	工作寬度	長度	最小加工徑	徑向前角		
Right / Left		DCON	WF	LF	DMIN	GAMF		
S10M-SDQCR/L07	DCMT0702	10	7	150	13	10°	CS25061S	FT-7
S12M-SDQCR/L07		12	9	150	16	8°	CS25061S	FT-7
S16Q-SDQCR/L07		16	11	180	20	6°	CS25061S	FT-7
S20R-SDQCR/L07		20	13	200	25	6°	CS25061S	FT-7
S16Q-SDQCR/L11	DCMT11T3	16	11	180	20	6°	CS35095	FT-15
S20R-SDQCR/L11		20	13	200	25	8°	CS35095	FT-15
S20S-SDQCR/L11		20	13	250	25	8°	CS35095	FT-15
S25R-SDQCR/L11		25	17	200	32	4°	CS35095	FT-15
S32S-SDQCR/L11		32	22	250	40	4°	CS35095	FT-15
S40T-SDQCR/L11		40	27	300	50	3°	CS35095	FT-15
S50U-SDQCR/L11		50	35	350	63	2°	CS35095	FT-15
C10M-SDQCR07	DCMT0702	10	7	150	13	10°	CS25061S	FT-7
C12Q-SDQCR07		12	9	180	16	7°	CS25061S	FT-7
C16R-SDQCR07		16	11	200	20	6°	CS25061S	FT-7
E10Q-SDQCR07	DCMT0702	10	7	180	13	10°	CS25061S	FT-7
E12R-SDQCR07		12	9	200	16	7°	CS25061S	FT-7
E16R-SDQCR07		16	11	200	20	6°	CS25061S	FT-7

A- Steel shank with coolant
亦可做中心出水鋼柄

S-SDUC
C-SDUC
E-SDUC

93°

S-Steel Shank 鋼柄
C-Carbide Shank 鎢鋼柄
E-Carbide Shank with Coolant 油孔鎢鋼柄

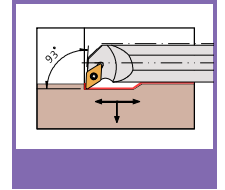
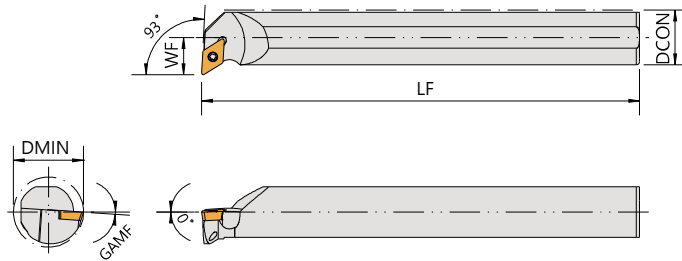

Order No.	Insert	Dimensions(mm)					Parts	Wrench
		柄徑	工作寬度	長度	最小加工徑	徑向前角		
Right / Left		DCON	WF	LF	DMIN	GAMF		
S10M-SDUCR/L07	DCMT0702	10	7	150	13	10°	CS25061S	FT-7
S12M-SDUCR/L07		12	9	150	16	8°	CS25061S	FT-7
S16Q-SDUCR/L07		16	11	180	20	6°	CS25061S	FT-7
S20R-SDUCR/L07		20	13	200	25	5°	CS25061S	FT-7
S16Q-SDUCR/L11	DCMT11T3	16	11	180	20	7°	CS35095	FT-15
S20R-SDUCR/L11		20	13	200	25	8°	CS35095	FT-15
S20S-SDUCR/L11		20	13	250	25	8°	CS35095	FT-15
S25R-SDUCR/L11		25	17	200	32	4°	CS35095	FT-15
S32S-SDUCR/L11		32	22	250	40	4°	CS35095	FT-15
S40T-SDUCR/L11		40	27	300	50	2°	CS35095	FT-15
C10M-SDUCR07	DCMT0702	10	7	150	13	10°	CS25061S	FT-7
C12Q-SDUCR07		12	9	180	16	8°	CS25061S	FT-7
C16R-SDUCR07		16	11	200	20	6°	CS25061S	FT-7
C16R-SDUCR11	DCMT11T3	16	11	200	20	7°	CS35095	FT-15
C20S-SDUCR11		20	13	250	25	8°	CS35095	FT-15
C25T-SDUCR11		25	17	300	32	4°	CS35095	FT-15
E10Q-SDUCR07	DCMT0702	10	7	180	13	10°	CS25061S	FT-7
E12R-SDUCR07		12	9	200	16	8°	CS25061S	FT-7
E16R-SDUCR07		16	11	200	20	6°	CS25061S	FT-7
E20S-SDUCR11	DCMT11T3	20	13	250	25	8°	CS35095	FT-15
E25T-SDUCR11		25	17	300	32	4°	CS35095	FT-15

A- Steel shank with coolant
亦可做中心出水鋼柄

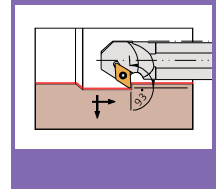
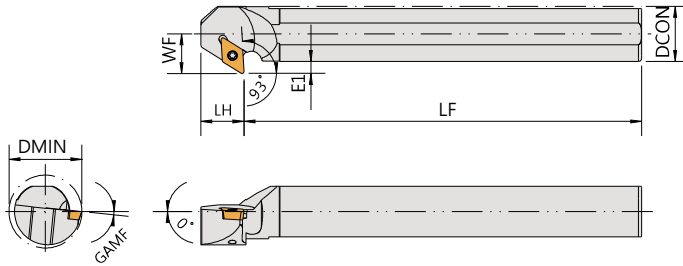
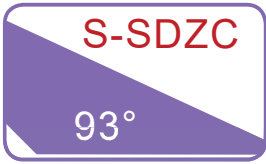

Order No.	Insert	Dimensions(mm)							Parts	Wrench
		柄徑 DCON	工作寬度 WF	切深 E1	長度 LF	最小加工徑 DMIN	頭長 LH	徑向前角 GAMF		
S10M-SDZCR/L07	DCMT0702	10	8.5	3.5	150	14	11	10°	CS25061S	FT-7
S12M-SDZCR/L07		12	10.5	4.5	150	17	11	9°	CS25061S	FT-7
S16Q-SDZCR/L07		16	12.5	4.5	180	21	11	8°	CS25061S	FT-7
S20R-SDZCR/L11	DCMT11T3	20	15.5	5.5	200	26	16	8°	CS35095	FT-15
S20S-SDZCR/L11		20	15.5	5.5	250	26	16	8°	CS35095	FT-15
S25R-SDZCR/L11		25	18	5.5	200	33	20	6°	CS35095	FT-15
S32S-SDZCR/L11		32	21.5	5.5	250	38	20	4°	CS35095	FT-15

A- Steel shank with coolant
亦可做中心出水鋼柄

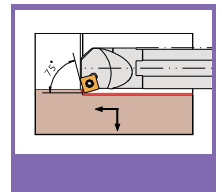
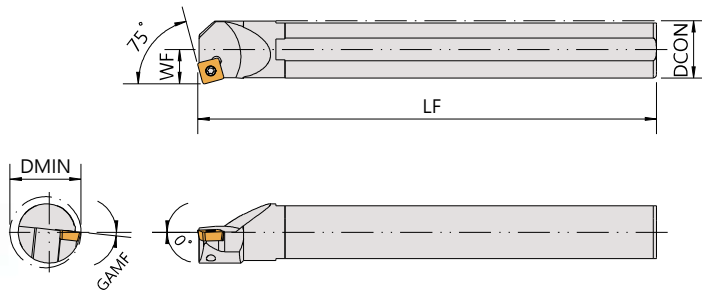

Order No.	Insert	Dimensions(mm)					Parts	Wrench
		柄徑 DCON	工作寬度 WF	長度 LF	最小加工徑 DMIN	徑向前角 GAMF		
S12M-SSKCR/L09	SCMT09T3	12	8.5	150	16	12°	CS40090	FT-15
S16Q-SSKCR/L09		16	11	180	20	11°	CS40090	FT-15
S20R-SSKCR/L09		20	13	200	25	6°	CS40090	FT-15
S25R-SSKCR/L09		25	15	200	31	6°	CS40090	FT-15
S25R-SSKCR/L12	SCMT1204	25	17	200	32	7°	CS40115	FT-15
S32S-SSKCR/L12		32	22	250	40	7°	CS40115	FT-15

A- Steel shank with coolant
亦可做中心出水鋼柄

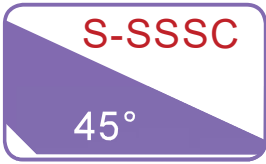

S-SSSC

45°

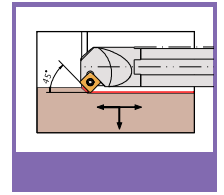
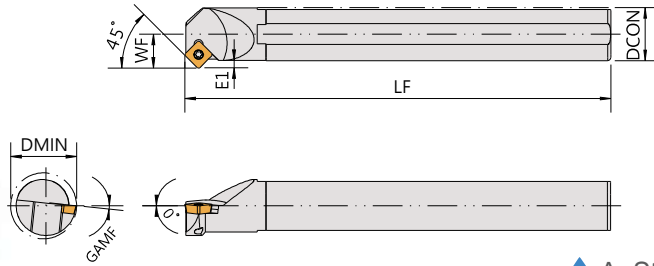

亦可做中心出水鋼柄
A- Steel shank with coolant

Order No.	Insert	Dimensions(mm)						Parts	Wrench
		柄徑	工作寬度	切深	長度	最小加工徑	徑向前角		
Right / Left		DCON	WF	E1	LF	DMIN	GAMF		
S12M-SSSCR/L09	SCMT09T3	12	8.5	2.5	150	16	12°	CS40090	FT-15
S16Q-SSSCR/L09		16	11.5	3.5	180	20	10°	CS40090	FT-15
S20R-SSSCR/L09		20	13.5	3.5	200	26	8°	CS40090	FT-15
S25R-SSSCR/L09		25	16	3.5	200	31	6°	CS40090	FT-15

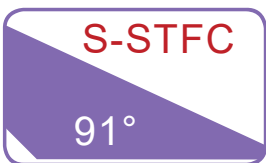

S-STFC

91°

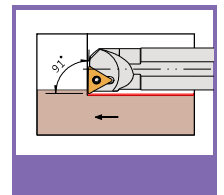
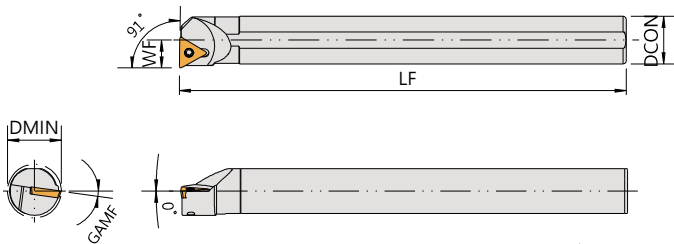

亦可做中心出水鋼柄
A- Steel shank with coolant

Order No.	Insert	Dimensions(mm)					Parts	Wrench	
		柄徑	工作寬度	長度	最小加工徑	徑向前角			
Right / Left		DCON	WF	LF	DMIN	GAMF			
S08H-STFCR/L09	TCMT0902	8	6	100	12	15°	CS22050	FT-7	
S10K-STFCR/L09		10	7	125	14	15°	CS22050	FT-7	
S12M-STFCR/L09		12	9	150	16	10°	CS22050	FT-7	
S10K-STFCR/L11	TCMT1102	10	7	125	14	12°	CS25061S	FT-7	
S12M-STFCR/L11		12	9	150	16	10°	CS25061S	FT-7	
S12M-STFCR/L11-14		12	7	150	14	10°	CS25061S	FT-7	
S16Q-STFCR/L11		16	11	180	20	6°	CS25061S	FT-7	
S16Q-STFCR/L11-18		16	9	180	18	8°	CS25061S	FT-7	
S20R-STFCR/L11		20	13	200	25	3°	CS25061S	FT-7	
S20S-STFCR/L11		20	13	250	25	3°	CS25061S	FT-7	
S20R-STFCR/L16		TCMT16T3	20	13	200	25	8°	CS35090	FT-15
S20S-STFCR/L16			20	13	250	25	8°	CS35090	FT-15
S25R-STFCR/L16			25	17	200	32	6°	CS35090	FT-15
S32S-STFCR/L16	32		22	250	39	4°	CS35090	FT-15	

C-STFC
E-STFC
L-STFC
91°

E-STFC

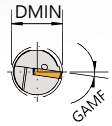
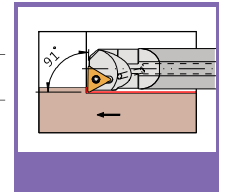
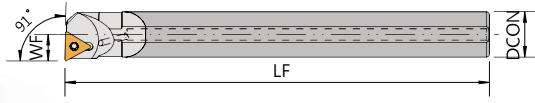

L-STFC

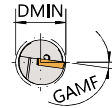
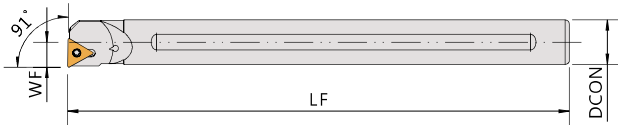

C-Carbide Shank 鎢鋼柄

E-Carbide Shank with Coolant 油孔鎢鋼柄

L-Anti-vibration Shank with Coolant 油孔耐震刀柄

Order No.	Insert	Dimensions(mm)					Parts	Wrench
		柄徑 DCON	工作寬度 WF	長度 LF	最小加工徑 DMIN	徑向前角 GAMF		
C08K-STFCR09-10	TCMT0902	8	5	125	10	15°	CS22050	FT-7
C10M-STFCR09-12		10	6	150	12	13°		
C12Q-STFCR09-14		12	7	180	14	10°		
C12Q-STFCR11-14	TCMT1102	12	7	180	14	10°	CS25061S	FT-7
C16R-STFCR11-18		16	9	200	18	8°		
C20S-STFCR11-22		20	11	250	22	6°		
C25T-STFCR16-28	TCMT16T3	25	14	300	28	6°	CS35090	FT-15
E08M-STFCR09-10	TCMT0902	8	5	150	10	15°	CS22050	FT-7
E10Q-STFCR09-12		10	6	180	12	13°		
E12R-STFCR11-14	TCMT1102	12	7	200	14	10°	CS25061S	FT-7
E16R-STFCR11-18		16	9	200	18	8°		
E20S-STFCR11-22		20	11	250	22	6°		
E25T-STFCR16-28	TCMT16T3	25	14	300	28	6°	CS35090	FT-15
L08K-STFCR09-10	TCMT0902	8	5	125	10	15°	CS22050	FT-7
L10K-STFCR11-12	TCMT1102	10	6	125	12	13°	CS25061S	FT-7
L12M-STFCR11-14		12	7	150	14	10°		
L16R-STFCR11-18		16	9	200	18	8°		

💧 A- Steel shank with coolant
亦可做中心出水鋼柄

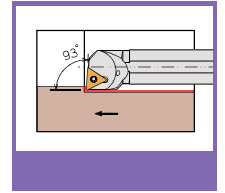
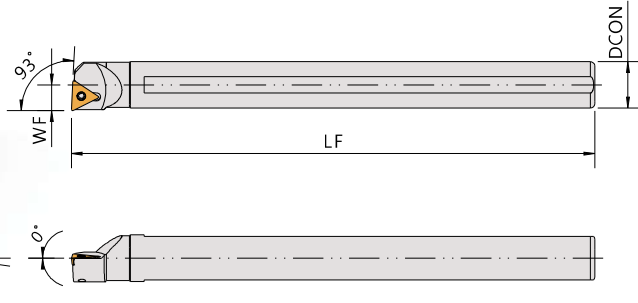
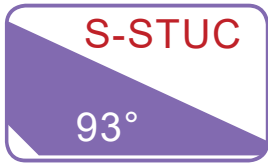

Order No.	Insert	Dimensions(mm)					Parts	Wrench	
		柄徑	工作寬度	長度	最小加工徑	徑向前角			
Right / Left		DCON	WF	LF	DMIN	GAMF			
S08K-STUCR/L09-10	TCMT0902	8	5	125	10	15°	CS22050	FT-7	
S10K-STUCR09-12		10	6	125	12	13°	CS22050	FT-7	
S10K-STUCR11	TCMT1102	10	7	125	14	12°	CS25061S	FT-7	
S10K-STUCR11-12		10	6	125	12	12°	CS25061S	FT-7	
S12M-STUCR11-14		12	7	150	14	10°	CS25061S	FT-7	
S16Q-STUCR11		16	11	180	18	8°	CS25061S	FT-7	
S16Q-STUCR11-18		16	9	180	18	8°	CS25061S	FT-7	
S20R-STUCR11-22		20	11	200	22	6°	CS25061S	FT-7	
S25R-STUCR1102-28		25	14	200	28	6°	CS25061S	FT-7	
S32S-STUCR1102		32	22	250	39	4°	CS25061S	FT-7	
S20R-STUCR16		TCMT16T3	20	13	200	25	6°	CS35090	FT-15
S20R-STUCR16-22			20	11	200	22	6°	CS35090	FT-15
S25R-STUCR16	25		17	200	32	6°	CS35090	FT-15	
S25R-STUCR16-28	25		14	200	28	6°	CS35090	FT-15	
S32S-STUCR16	32		22	250	39	4°	CS35090	FT-15	

A- Steel shank with coolant
亦可做中心出水鋼柄

C-STUC
E-STUC
93°

C-Carbide Shank 鎢鋼柄
E-Carbide Shank with Coolant 油孔鎢鋼柄

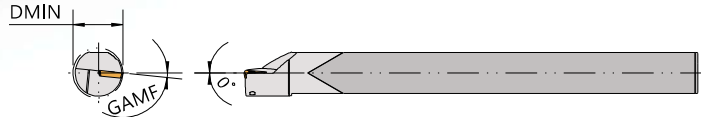
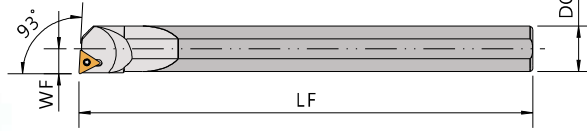
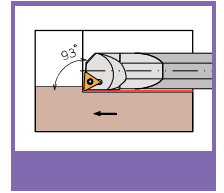

Order No.	Insert	Dimensions(mm)					Parts	Wrench
		柄徑	工作寬度	長度	最小加工徑	徑向前角		
Right / Left		DCON	WF	LF	DMIN	GAMF		
C08K-STUCR09-10	TCMT0902	8	5	125	10	15°	CS22050	FT-7
C10M-STUCR09-12		10	6	150	12	13°	CS22050	FT-7
C10M-STUCR11-12	TCMT1102	10	6	150	12	13°	CS25061S	FT-7
C12Q-STUCR11-14		12	7	180	14	10°	CS25061S	FT-7
C16Q-STUCR11-18		16	9	180	18	8°	CS25061S	FT-7
C16R-STUCR11-18		16	9	200	18	8°	CS25061S	FT-7
C20R-STUCR11-22		20	11	200	22	6°	CS25061S	FT-7
C20S-STUCR1102-22		20	11	250	22	6°	CS25061S	FT-7
C20R-STUCR16		TCMT16T3	20	11	200	22	6°	CS35090
C25T-STUCR16	25		14	300	28	6°	CS35090	FT-15
E20R-STUCR16-22	TCMT16T3	20	11	200	22	6°	CS35090	FT-15

A- Steel shank with coolant
亦可做中心出水鋼柄

S-STUB
S-STUP
93°



S-STUB

S-STUP

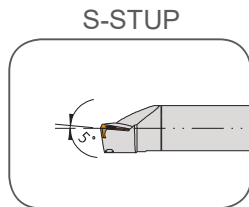

S-STUP

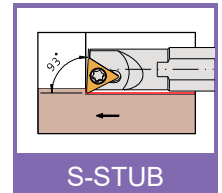
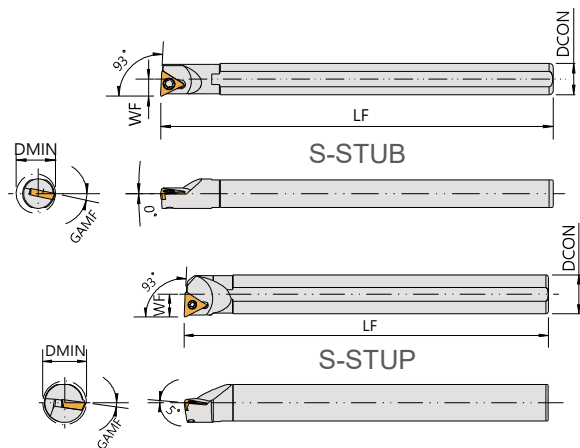

S-STUB

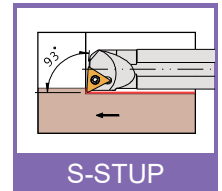

S-STUP

Order No.	Insert	Dimensions(mm)					Parts	Wrench
		柄徑	工作寬度	長度	最小加工徑	徑向前角		
Right / Left		DCON	WF	LF	DMIN	GAMF		
S08H-STUBR/L06-10	TBMT0601	8	4	100	10	12°	CS20038	FT-6
S08H-STUPR/L08	TPGT0802	8	6	100	12	12°	CS20045	FT-6
S08H-STUPR/L08-10		8	5	100	10	12°	CS20045	FT-6
S08H-STUPR/L09	TPMT0902	8	6	100	12	10°	CS25055 / CS25052S	FT-8
S08H-STUPR/L09-10		8	5	100	10	12°		FT-8
S10K-STUPR/L09		10	7	125	14	8°	CS25065 / CS25062S	FT-8
S10K-STUPR/L09-12		10	6	125	12	8°		FT-8
S12M-STUPR/L09	TPMT1103	12	9	150	16	5°	CSA30060	FT-8
S12M-STUPR/L09-14		12	7	150	14	5°		FT-8
S10K-STUPR/L11-12	TPMT1103	10	6	125	12	8°	CSA30060	FT-10
S10M-STUPR/L11		10	7	150	14	8°	CSA30060	FT-10
S12M-STUPR/L11		12	9	150	16	6°	CSA30060	FT-10
S12M-STUPR/L11-14		12	7	150	14	7°	CSA30060	FT-10
S16Q-STUPR/L11		16	11	180	20	2°	CSA30070	FT-10
S16Q-STUPR/L11-18		16	9	180	18	4°	CSA30070	FT-10
S20R-STUPR/L11		20	13	200	25	2°	CSA30070	FT-10
S20R-STUPR/L11-22		20	11	200	22	2°	CSA30070	FT-10
S20R-STUPR/L16	TPMT1604	20	13	200	25	8°	CS40090	FT-15
S20R-STUPR/L16-22		20	11	200	22	8°	CS40090	FT-15
S25R-STUPR/L16		25	17	200	32	8°	CS40090	FT-15
S25R-STUPR/L16-28		25	14	200	28	8°	CS40090	FT-15
S32S-STUPR/L16		32	22	250	40	6°	CS40090	FT-15
S32S-STUPR/L16-36		32	18	250	36	6°	CS40090	FT-15

A- Steel shank with coolant
亦可做中心出水鋼柄

**C-STUB/P
E-STUB/P**
93°

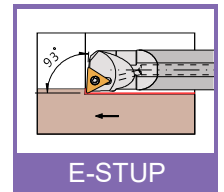
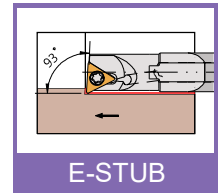
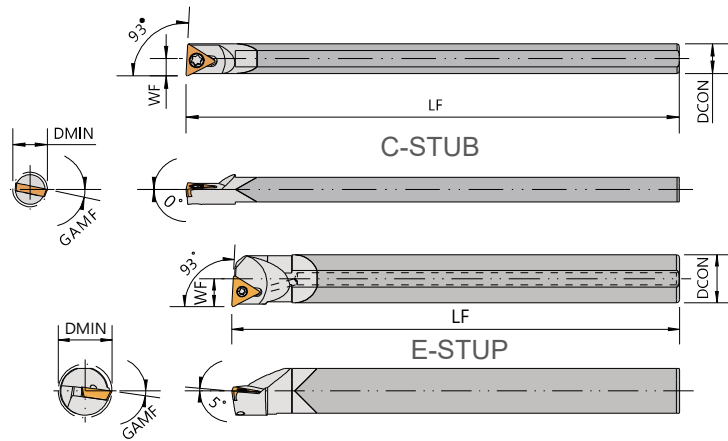

C-Carbide Shank 鑄鋼柄

E-Carbide Shank with Coolant 油孔鑄鋼柄

Order No.	Insert	Dimensions(mm)					Parts	Wrench
		柄徑 DCON	工作寬度 WF	長度 LF	最小加工徑 DMIN	徑向前角 GAMF		
C06H-STUBR06-07	TBMT0601	6	3.5	100	7	12°	CS20038	FT-6
C08K-STUBR06-08		8	4	125	8	10°	CS20038	FT-6
C08K-STUPR08-10	TPGT0802	8	5	125	10	10°	CS20045	FT-6
C10M-STUPR08-12		10	6	150	12	8°	CS20045	FT-6
C08K-STUPR09-10	TPMT0902	8	5	125	10	10°	CS25055 / CS25052S	FT-8
C10M-STUPR09-12		10	6	150	12	8°	CS25065/ CS25062S	FT-8
C10M-STUPR11-12	TPMT1103	10	6	150	12	8°	CSA30060	FT-10
C12Q-STUPR11-14		12	7	180	14	7°	CSA30060	FT-10
C16R-STUPR11-18		16	9	200	18	4°	CSA30070	FT-10
C20S-STUPR11-22		20	11	250	22	2°	CSA30070	FT-10
C20S-STUPR16-22	TPMT1604	20	11	250	22	2°	CS40090	FT-15
C25T-STUPR16-28		25	14	300	28	2°	CS40090	FT-15
E06K-STUBR06-07	TBMT0601	6	3.5	125	7	12°	CS20038	FT-6
E08M-STUPR08-10	TPMT0802	8	5	150	10	10°	CS20045	FT-6
E10Q-STUPR08-12		10	6	180	12	8°	CS20045	FT-6
E10Q-STUPR09-12	TPMT0902	10	6	180	12	8°	CS25065/ CS25062S	FT-8
E10Q-STUPR11-12	TPMT1103	10	6	180	12	8°	CSA30060	FT-10
E12R-STUPR11-14		12	7	200	14	7°	CSA30060	FT-10
E16R-STUPR11-18		16	9	200	18	4°	CSA30070	FT-10
E20S-STUPR11-22		20	11	250	22	2°	CSA30070	FT-10
E20S-STUPR16-22	TPMT1604	20	11	250	22	2°	CS40090	FT-15
E25T-STUPR16-28		25	14	300	28	2°	CS40090	FT-15

🔹 A- Steel shank with coolant
亦可做中心出水鋼柄

S-STWB
S-STWC

60°

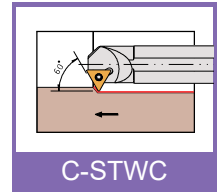
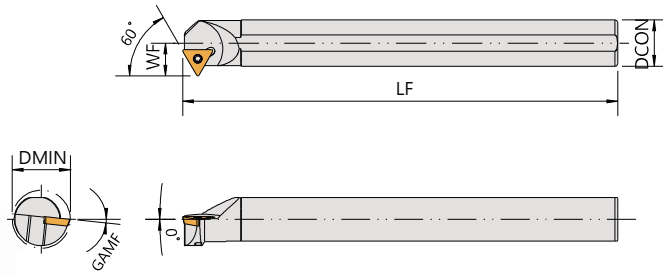

亦可做中心出水鋼柄
A- Steel shank with coolant

Order No.	Insert	Dimensions(mm)					Parts	Wrench	
		柄徑	工作寬度	長度	最小加工徑	徑向前角			
Right / Left		DCON	WF	LF	DMIN	GAMF			
S08H-STWBR06	TBMT0601	8	6	100	11	13°	CS20038	FT-6	
S08H-STWCR/L09	TCMT0902	8	6	100	10	13°	CS22050	FT-7	
S10K-STWCR/L09		10	7	125	13	8°	CS22050	FT-7	
S10K-STWCR/L11	TCMT1102	10	7	125	13	8°	CS25061S	FT-7	
S12M-STWCR/L11		12	9	150	16	8°	CS25061S	FT-7	
S16Q-STWCR/L11		16	11	180	20	6°	CS25061S	FT-7	
S20R-STWCR/L11		20	13	200	25	4°	CS25061S	FT-7	
S25R-STWCR/L11		25	15	200	31	6°	CS25061S	FT-7	
S20R-STWCR/L16		TCMT16T3	20	14.5	200	25	2°	CS35090	FT-15
S25R-STWCR/L16			25	17	200	32	6°	CS35090	FT-15
S32S-STWCR/L16	32		20.5	250	39	4°	CS35090	FT-15	
S40T-STWCR/L16	40		24	300	50	0°	CS35090	FT-15	

S-STWP

60°

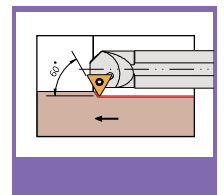
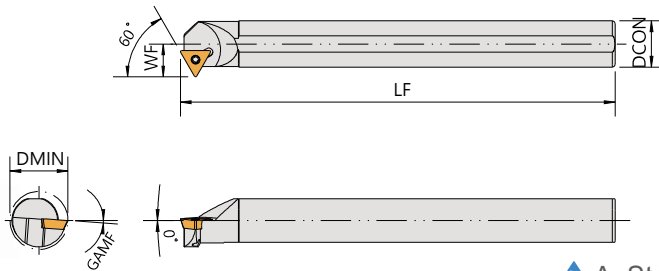

亦可做中心出水鋼柄
A- Steel shank with coolant

Order No.	Insert	Dimensions(mm)					Parts	Wrench
		柄徑	工作寬度	長度	最小加工徑	徑向前角		
Right / Left		DCON	WF	LF	DMIN	GAMF		
S08K-STWPR/L08	TPMT0802	8	6	125	11	10°	CS20045	FT-6
S08K-STWPR/L08-09		8	4.6	125	9	10°	CS20045	FT-6
S10K-STWPR/L09	TPMT0902	10	7	125	13	8°	CS25065 / CS25062S	FT-8
S10K-STWPR/L11	TPMT1103	10	7	125	13	8°	CSA30060	FT-10
S12M-STWPR/L11		12	9	150	16	5°	CSA30060	FT-10
S16Q-STWPR/L11		16	11	180	20	4°	CSA30070	FT-10
S20R-STWPR/L11		20	13	200	25	3°	CSA30070	FT-10

S-SVJB-E
S-SVJC-E
93°

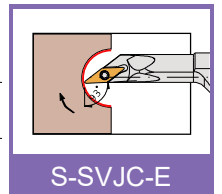
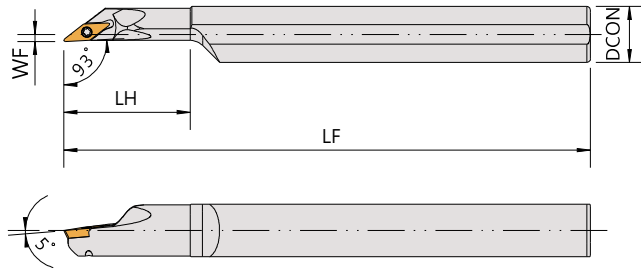
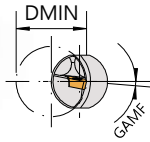

Order No.	Insert	Dimensions(mm)						Parts	Wrench
		柄徑	工作寬度	長度	最小加工徑	頭長	徑向前角		
Right / Left		DCON	WF	LF	DMIN	LH	GAMF		
S20R-SVJBR11-25E	VBMT1103	20	2	200	25	38	5°	CS25061S	FT-7
S25R-SVJBR11-30E		25	2	200	30	45.5	5°	CS25061S	FT-7
S32S-SVJBR16-40E	VBMT1604	32	2	250	40	60.5	5°	CS35090	FT-15
S12M-SVJCR08-16E	VCMT0802	12	2	150	16	26.5	5°	CS20045	FT-6
S16Q-SVJCR08-20E		16	2	180	20	36.5	5°	CS20045	FT-6

💧 A- Steel shank with coolant
亦可做中心出水鋼柄

S-SVJC
93°

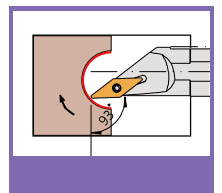
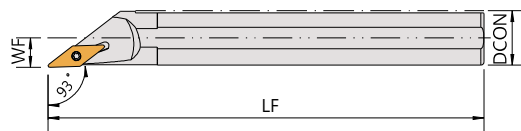
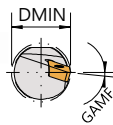

Order No.	Insert	Dimensions(mm)					Parts	Wrench
		柄徑	工作寬度	長度	最小加工徑	徑向前角		
Right / Left		DCON	WF	LF	DMIN	GAMF		
S12M-SVJCR/L11	VCMT1103	12	7	150	14	7°	CS25061S	FT-7
S16Q-SVJCR/L11		16	9	180	18	7°	CS25061S	FT-7
S16Q-SVJCR/L16	VCMT1604	16	9	180	18	7°	CS35090	FT-15
S20R-SVJCR/L16		20	10.5	200	21	6°	CS35090	FT-15
S25R-SVJCR/L16		25	13.5	200	27	6°	CS35090	FT-15
S32S-SVJCR/L16		32	17	250	34	4°	CS35090	FT-15
S40T-SVJCR/L16		40	22	300	44	4°	CS35090	FT-15

💧 A- Steel shank with coolant
亦可做中心出水鋼柄

S-SVPB
117.5°

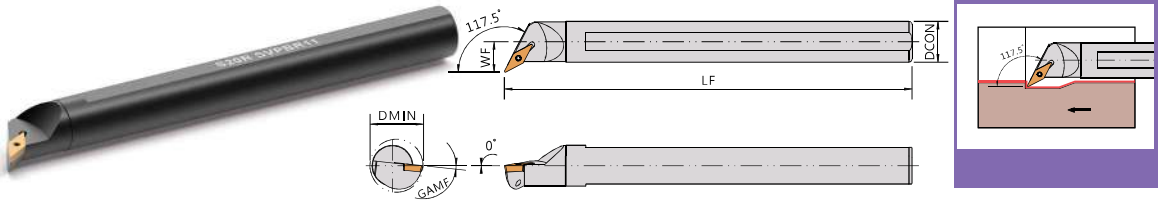

Order No.	Insert	Dimensions(mm)					Parts	Wrench
Right / Left		柄徑	工作寬度	長度	最小加工徑	徑向前角		
		DCON	WF	LF	DMIN	GAMF		
S12M-SVPBR/L11	VBMT1103	12	11	150	18	10°	CS25061S	FT-7
S16Q-SVPBR/L11		16	13	180	23	7°	CS25061S	FT-7
S20R-SVPBR/L11		20	15	200	26	6°	CS25061S	FT-7

💧 A- Steel shank with coolant 亦可做中心出水鋼柄

S-SVPC
117.5°

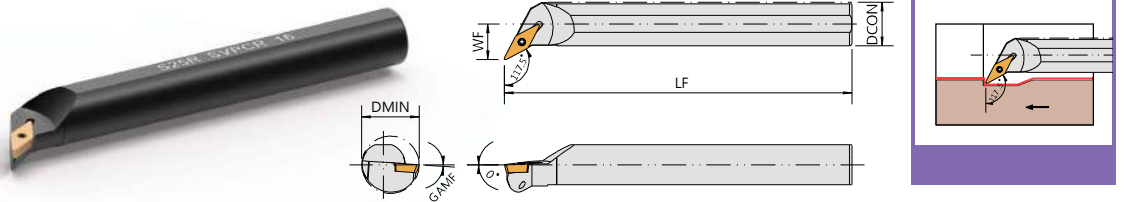

Order No.	Insert	Dimensions(mm)					Parts	Wrench
Right / Left		柄徑	工作寬度	長度	最小加工徑	徑向前角		
		DCON	WF	LF	DMIN	GAMF		
S12M-SVPCR/L11	VCMT1103	12	11	150	18	10°	CS25061S	FT-7
S16Q-SVPCR/L11		16	13	180	22	7°	CS25061S	FT-7
S20R-SVPCR/L11		20	15	200	27	6°	CS25061S	FT-7
S20R-SVPCR/L16	VCMT1604	20	19	200	30	8°	CS35090	FT-15
S25R-SVPCR/L16		25	20.5	200	34	4°	CS35090	FT-15
S32S-SVPCR/L16		32	22.5	250	41	8°	CS35090	FT-15
S40T-SVPCR/L16		40	27	300	50	6°	CS35090	FT-15

💧 A- Steel shank with coolant 亦可做中心出水鋼柄

S-SVQB
S-SVQC

107.5°

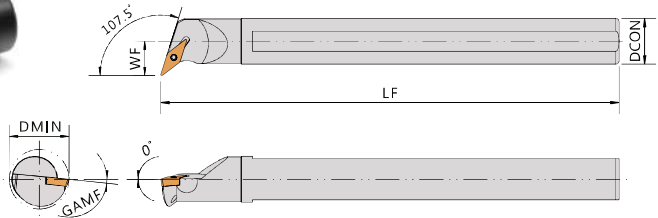
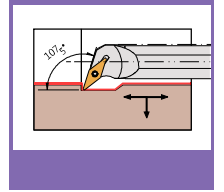

Order No.	Insert	Dimensions(mm)					Parts	Wrench
		柄徑	工作寬度	長度	最小加工徑	徑向前角		
Right / Left		DCON	WF	LF	DMIN	GAMF		
S12M-SVQBR/L11	VBMT1103	12	11	150	18	6°	CS25055PS	FT-7
S16Q-SVQBR/L11		16	13	180	22	6°	CS25055PS	FT-7
S20R-SVQBR/L11		20	15	200	26	6°	CS25055PS	FT-7
S20R-SVQBR/L16	VBMT1604	20	19	200	30	8°	CS35119S	FT-15
S25R-SVQBR/L16		25	20.5	200	34	4°	CS35119S	FT-15
S32S-SVQBR/L16		32	22.5	250	40	8°	CS35119S	FT-15
S40V-SVQBR/L16		40	27	400	48	6°	CS35119S	FT-15

Order No.	Insert	Dimensions(mm)					Parts	Wrench
		柄徑	工作寬度	長度	最小加工徑	徑向前角		
Right / Left		DCON	WF	LF	DMIN	GAMF		
S12M-SVQCR/L11	VCMT1103	12	11	150	18	10°	CS25061S	FT-7
S16Q-SVQCR/L11		16	13	180	22	7°	CS25061S	FT-7
S20R-SVQCR/L11		20	15	200	27	6°	CS25061S	FT-7
S20R-SVQCR/L16	VCMT1604	20	19	200	30	8°	CS35090	FT-15
S25R-SVQCR/L16		25	20.5	200	34	4°	CS35090	FT-15
S32S-SVQCR/L16		32	22.5	250	41	8°	CS35090	FT-15
S40T-SVQCR/L16		40	27	300	50	6°	CS35090	FT-15

A- Steel shank with coolant 亦可做中心出水鋼柄

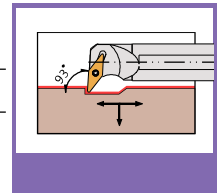
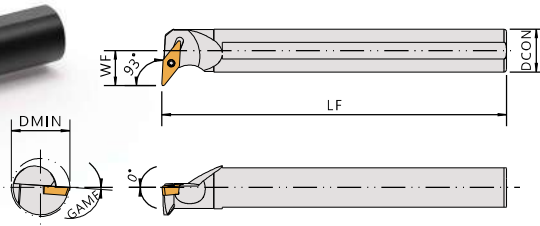
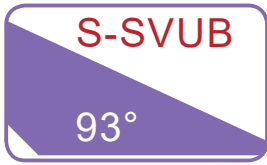

Order No.	Insert	Dimensions(mm)					Parts	Wrench
		柄徑 DCON	工作寬度 WF	長度 LF	最小加工徑 DMIN	徑向前角 GAMF		
Right / Left								
S16Q-SVUBR/L11	VBMT1103	16	13	180	22	7°	CS25061S	FT-7
S20R-SVUBR/L11		20	15	200	27	6°	CS25061S	FT-7
S25R-SVUBR/L11		25	20.5	200	33	4°	CS25061S	FT-7
S20R-SVUBR/L16	VBMT1604	20	19	200	31	8°	CS35090	FT-15
S25R-SVUBR/L16		25	20.5	200	34	4°	CS35090	FT-15
S32S-SVUBR/L16		32	22.5	250	42	8°	CS35090	FT-15
S32U-SVUBR/L16		32	22.5	350	42	8°	CS35090	FT-15
S40V-SVUBR/L16		40	27	400	51	6°	CS35090	FT-15
S50V-SVUBR/L16		50	32	400	58	6°	CS35090	FT-15

A- Steel shank with coolant
亦可做中心出水鋼柄

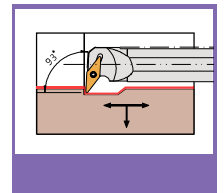
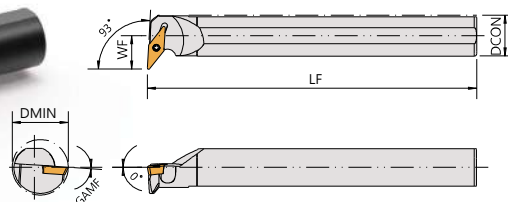
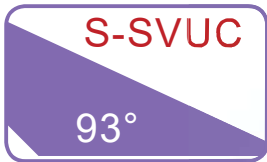

Order No.	Insert	Dimensions(mm)					Parts	Wrench
		柄徑 DCON	工作寬度 WF	長度 LF	最小加工徑 DMIN	徑向前角 GAMF		
Right / Left								
S12M-SVUCR/L08	VCMT0802	12	11	150	22	7°	CS20045	FT-7
S16Q-SVUCR/L11	VCMT1103	16	13	180	22	7°	CS25061S	FT-7
S20R-SVUCR/L11		20	15	200	27	6°	CS25061S	FT-7
S25R-SVUCR/L11		25	20.5	200	33	4°	CS25061S	FT-7
S20R-SVUCR/L16	VCMT1604	20	19	200	31	8°	CS35090	FT-15
S25R-SVUCR/L16		25	20.5	200	33	7°	CS35090	FT-15
S32S-SVUCR/L16		32	22.5	250	42	5°	CS35090	FT-15
S40T-SVUCR/L16		40	27	300	51	4°	CS35090	FT-15

A- Steel shank with coolant
亦可做中心出水鋼柄

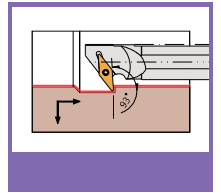
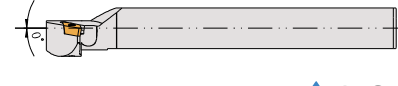
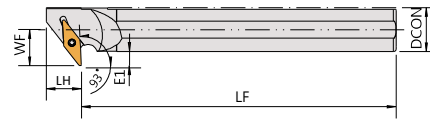
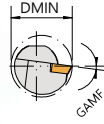
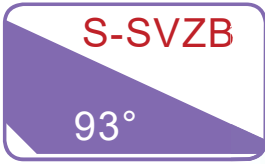

亦可做中心出水鋼柄

A- Steel shank with coolant

Order No.	Insert	Dimensions(mm)							Parts	Wrench
		柄徑	工作寬度	切深	長度	最小加工徑	頭長	徑向前角		
Right / Left		DCON	WF	E1	LF	DMIN	LH	GAMF		
S16Q-SVZBR/L11	VBMT1103	16	10.5	2.5	180	19	10	7.5°	CS25061S	FT-7
S20R-SVZBR/L11		20	14	4	200	25	10	7.5°		
S20R-SVZBR/L16	VBMT1604	20	17	7	200	30	20	7.5°	CS35090	FT-15
S25R-SVZBR/L16		25	19.5	7	200	35	20	7.5°		
S32S-SVZBR/L16		32	23	7	250	40	20	7.5°		

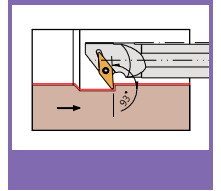
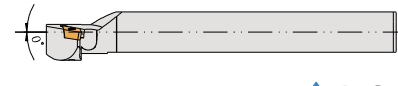
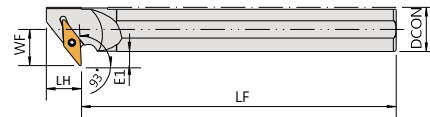
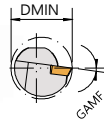
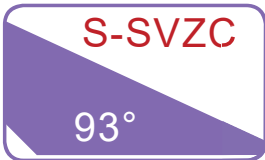

亦可做中心出水鋼柄

A- Steel shank with coolant

Order No.	Insert	Dimensions(mm)							Parts	Wrench
		柄徑	工作寬度	切深	長度	最小加工徑	頭長	徑向前角		
Right / Left		DCON	WF	E1	LF	DMIN	LH	GAMF		
S16Q-SVZCR/L11	VCMT1103	16	13	5	180	22	10	7.5°	CS25061S	FT-7
S20R-SVZCR/L11		20	15	5	200	26	10	7.5°		
S20R-SVZCR/L16	VCMT1604	20	17	7	200	30	17	7.5°	CS35090	FT-15
S25R-SVZCR/L16		25	19.5	7	200	35	20	7.5°		
S32S-SVZCR/L16		32	23	7	250	40	20	7.5°		
S40T-SVZCR/L16		40	27	7	300	50	20	7.5°		

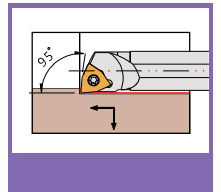
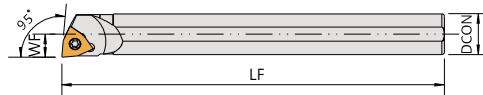
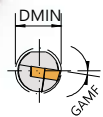
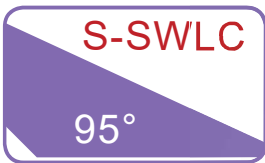

亦可做中心出水鋼柄

A- Steel shank with coolant

▼ Recommended Inserts 建議刀片品牌: MITSUBISHI

Order No.	Insert	Dimensions(mm)					Parts	Wrench
		柄徑	工作寬度	長度	最小加工徑	徑向前角		
Right / Left		DCON	WF	LF	DMIN	GAMF		
S08H-SWLCR03-10	WCMT0302	8	5	100	10	13°	CS25055 / CS25052S	FT-8
S10K-SWLCR03-12		10	6	125	12	12°		
S12M-SWLCR03-14		12	7	150	14	9°		
S12M-SWLCR06-14	WCMT06T3	12	7	150	14	12°	CS40090	FT-15
S16Q-SWLCR06-18		16	9	180	18	9°		
S20R-SWLCR06-22		20	11	200	22	7°		

S-SCLC
C-SCLC

95°

S-SCLC

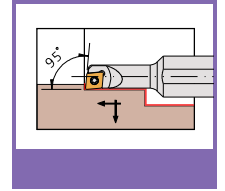
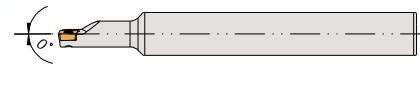
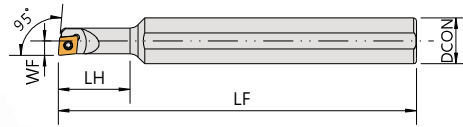
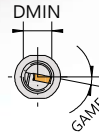

C-SCLC

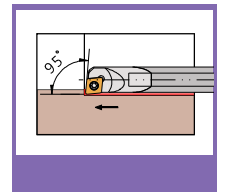
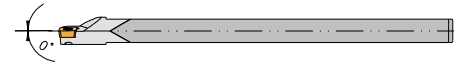
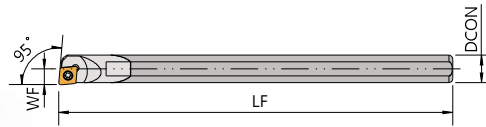
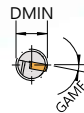

小徑刀

Order No.	Insert	Dimensions(mm)						Parts	Wrench
		柄徑	工作寬度	長度	最小加工徑	頭長	徑向前角		
Right / Left		DCON	WF	LF	DMIN	LH	GAMF		
S12K-SCLCR04-06	CCGT04T0	12	3	125	6	15	13°	CS20038	FT-6
S12K-SCLCR04-07		12	3.5	125	7	15	13°	CS20038	FT-6
S16K-SCLCR06-08	CCMT0602	16	4	125	8	20	15°	CS25050	FT-7
S16K-SCLCR06-09		16	4.5	125	9	25	12°	CS25050	FT-7
S16K-SCLCR06-10		16	5	125	10	25	11°	CS25050	FT-7

Carbide Shank 錐鋼柄

Order No.	Insert	Dimensions(mm)					Parts	Wrench
		柄徑	工作寬度	長度	最小加工徑	徑向前角		
Right / Left		DCON	WF	LF	DMIN	GAMF		
C04G-SCLCR03-05	CCGT03S1	4	2.5	90	5	15°	CS16031	FT-6
C05H-SCLCR03-06		5	3.0	100	6	13°	CS16031	FT-6
C05H-SCLCR04-06	CCGT04T0	5	3.0	100	6	13°	CS20038	FT-6
C06H-SCLCR04-07		6	3.5	100	7	13°	CS20038	FT-6
C07H-SCLCR04-08		7	4.0	100	8	11°	CS20038	FT-6

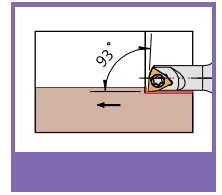
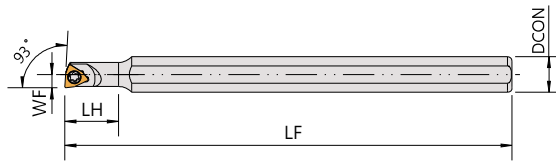
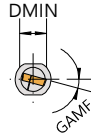
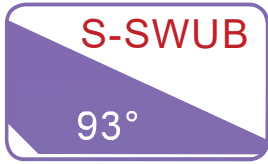

▼Recommended Inserts 建議刀片品牌: MITSUBISHI / KYOCERA

Order No.	Insert	Dimensions(mm)						Parts	Wrench
		柄徑	工作寬度	長度	最小加工徑	頭長	徑向前角		
Right / Left		DCON	WF	LF	DMIN	LH	GAMF		
S08H-SWUBR/L06-5.5	WBG0601	8	3	100	5.5	18	15°	CS20038	FT-6
S08H-SWUBR/L06-07		8	3.5	100	7	18	13°	CS20038	FT-6
S08H-SWUBR/L06-10		8	5	100	10	-	13°	CS20038	FT-6
S16K-SWUBR/L06-5.5		16	3	125	5.5	12	15°	CS20038	FT-6
S10K-SWUBR/L08-12	WBG0802	10	6	125	12	-	11°	CS20045	FT-6
S12M-SWUBR/L08-14		12	7	150	14	-	11°	CS20045	FT-6

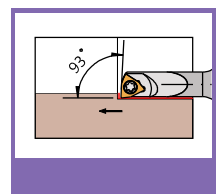
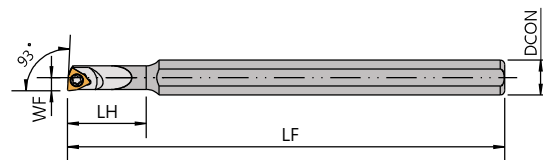
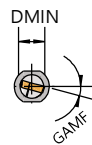
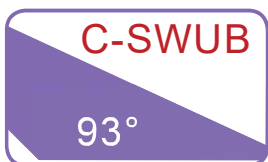

Carbide Shank 鎢鋼柄

▼Recommended Inserts 建議刀片品牌: MITSUBISHI / KYOCERA

Order No.	Insert	Dimensions(mm)						Parts	Wrench
		柄徑	工作寬度	長度	最小加工徑	頭長	徑向前角		
Right / Left		DCON	WF	LF	DMIN	LH	GAMF		
C05H-SWUBR06-5.5	WBG0601	5	3.0	100	5.5	-	15°	CS20038	FT-6
C06H-SWUBR06-07		6	3.5	100	7	-	13°	CS20038	
C07H-SWUBR06-08		7	4.0	100	8	-	13°	CS20038	
C08K-SWUBR06-5.5		8	3.0	125	5.5	30	13°	CS20038	

Mini Boring Bar Sleeve 套筒

HMD



HMB

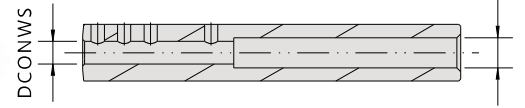
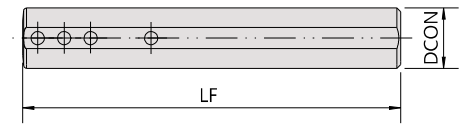
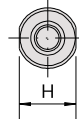

Order No.	Dimensions(mm)			Screw	Wrench			
Right / Left	刀具安裝直徑	柄徑	長度					
	DCONWS	DCON	LF					
HMB1603	3	16	100	CS9-4004	LW020			
HMB1604	4							
HMB1605	5							
HMB1606	6							
HMB1607	7			CS9-5005	LW025			
HMB1608	8							
HMB2003	3					20	CS9-4004	LW020
HMB2004	4							
HMB2005	5							
HMB2006	6							
HMB2007	7	CS9-5005	LW025					
HMB2008	8							
HMBN1203	3	19.05	100	CS9-4004	LW020			
HMBN1204	4							
HMBN1205	5							
HMBN1206	6			CS9-5005	LW025			
HMBN1207	7							
HMBN1208	8							
HMBN1604	4	25.4	120	CS9-4004	LW020			
HMBN1605	5							
HMBN1606	6			CS9-5005	LW025			
HMBN1608	8							
HMD1604	4	16	100	CS9-4004	LW020			
HMD1605	5							
HMD1606	6			CS9-5005	LW025			
HMD1607	7							
HMD2004	4	20	100	CS9-4004	LW020			
HMD2005	5							
HMD2006	6			CS9-5005	LW025			
HMD2007	7							